

Digital UV SENSOR “UV-Surface-D” (DIGIPROBE)

Standard surface-mount 180° FOV digital UV Sensor



UV Sensor “UV-Surface-D”

Standard surface-mount 180° FOV UV Sensor



UV-Surface-D

What is a Digital Sensor?

The sglux digital sensors convert the photocurrent generated by a Silicon Carbide (SiC) UV-photodiode into a numeric information. The digital sensors use the CAN bus protocol which is known from automotive applications. The benefit of a digital sensor compared with an analog sensor is a large dynamic range of 5 orders of magnitude (3 orders of magnitude if an analog sensor is used). Another benefit is an almost unlimited cable length and a perfect protection against electromagnetic influences.

Shall I use an analog or a digital sensor?

Today, most industrial optical sensor applications base on analog signal conversion technology where a voltage or current output is connected to the customer's analog input controller. These easy to apply analog sensors cover a broad range of applications. The main benefit of a digital probe is its large dynamic range which allows to measure low radiation and strong radiation without changing the probe. An example is UV transmission measurement in waste water where the transmission changes within a large range depending on the water's pollution. A scientific lab should always use a digital probe instead of an analog probe due to higher versatility.

How to use the sglux digital sensors?

The digital sensors are connected to the sglux UVTOUCH radiometer or to customer's CAN bus controller. Alternatively, the sglux DIGIBOX (CAN-to-USB converter) is available where up to eight digital sensors can be connected. This box can be directly wired to the computer's USB port.

Description of the UV Sensor “UV-Surface-D”

The digital sensor **UV-Surface-D** is a cosine corrected sensor to be used for industrial or scientific UV radiation measurements of radiation arriving at a surface, horizontal or vertical or any other orientation.

Configuration Facilities

Page 3 of this datasheet guides through an individual configuration procedure which allows to select the spectral response (STEP 1) and the sensitivity range (STEP 2) for your order.

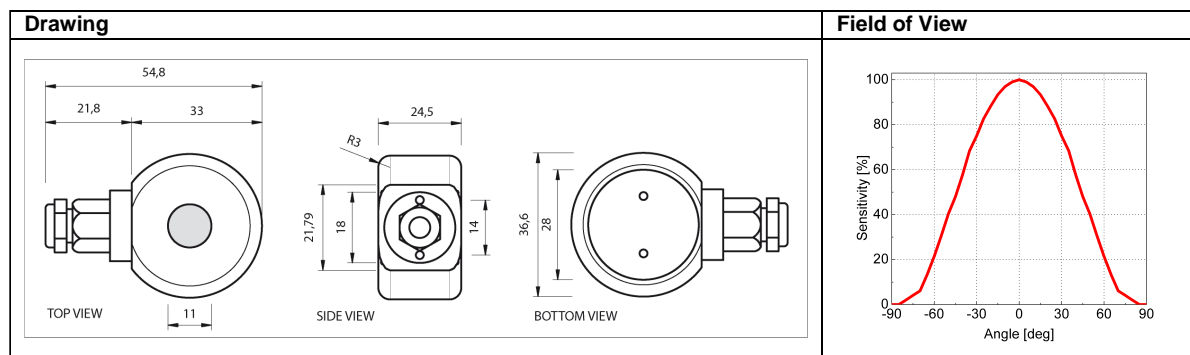

Digital UV SENSOR “UV-Surface-D” (DIGIPROBE)

Standard surface-mount 180° FOV digital UV Sensor



Specifications

Fixed Specifications

Parameter	Value
Dimensions	please refer to the drawing
Signal Output	CAN bus signal, 125kbit/s Pins 1, 7=CAN low, Pins 3, 8= CAN high Pins 2, 4, 5=GND
VSCP protocol according to the following specifications: http://sourceforge.net/projects/m2m/files/VSCP%20Specification/	
Connection	2m cable with 8-Pin male connector (to converter or else)
Temp. Coefficient	<0,1%/K
Operating Temp.	-20...+80°C
Humidity	<80%, non condensing (water submersible on request)

Configurable Specifications

Parameter	Value
Absolute Sensitivity	100nW/cm ² ... 1mW/cm ² or 5µW/cm ² ... 50mW/cm ² or 1mW/cm ² ... 10W/cm ²
Spectral Sensitivity	UV-Broadband, UVA, UVB, UVC, UV-Index, UV+Blue, Blue

Please find the configuration guide at page 3 of this datasheet.

Accessories



UV TOUCH Radiometer

- 100% touch-screen controlled
- Dosimetry and datalogging
- Digital signal transmission from sensor (CAN bus)
- Compliant with GLP and LIMS standard
- Intuitive handling



CAN-to-USB converter box "DIGIBOX"

The DIGIBOX connects up to eight digital sglux UV sensors and evaluates their signal on a PC. The freeware „DigiLog“ has a logging function and shows actual values and trends. The software can also be used for sensor calibration.

The bundle DIGITAL SENSOR & DIGIBOX is a plug&play solution for high performance laboratory UV measurements.

Calibration

We are pleased to issue an individual quotation for NIST or PTB traceable calibration.

Digital UV SENSOR “UV-Surface-D” (DIGIPROBE)

Standard surface-mount 180° FOV digital UV Sensor



Configuration Guide

STEP 1 → Configuration of the Spectral Sensitivity

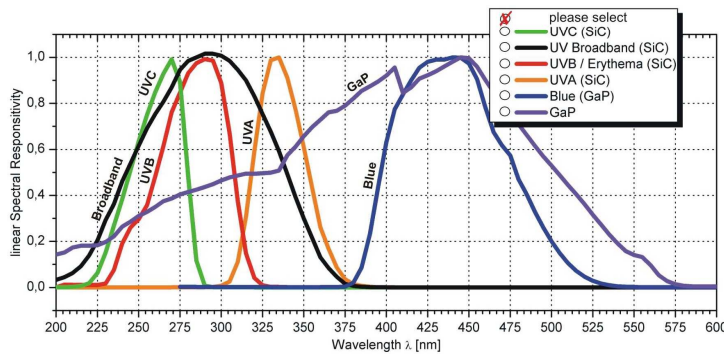

Please select one spectral sensitivity curve.

STEP 2 → Sensitivity

We configure the digital UV sensor for intensities across 10 orders of magnitude from 100nW/cm² to 10W/cm². Please select from our standard ranges listed below. Other ranges are available on request.

sglux standard ranges

- 100nW/cm² ... 1mW/cm²
 μW/cm² ... 50mW/cm²
 1mW/cm² ... 10W/cm²

Probe mechanical design overview

Besides the ticked mechanical design of this datasheet other mechanical designs are available.

<input checked="" type="checkbox"/> Type	Description
<input checked="" type="checkbox"/> UV-Surface-D	Digital Standard surface-mount 180° FOV UV Sensor (this datasheet)
<input type="checkbox"/> UV-Air-D	Digital Axis oriented in-chamber UV Sensor
<input type="checkbox"/> UV-Cosine-D	Digital Waterproof UV Sensor for outdoor use
<input type="checkbox"/> UV-Water-D	Digital 10 bar water pressure proof UV Sensor
<input type="checkbox"/> UV-DVGW-D	Digital UV Sensor for DVGW certified water purifiers