



ROM

SUNSTAR传感与控制 <http://www.sensor-ic.com/> TEL:0755-83376549 FAX:0755-83376182 E-MAIL:szss20@163.com



RTD On Membrane - Mikroflowsens- Technology

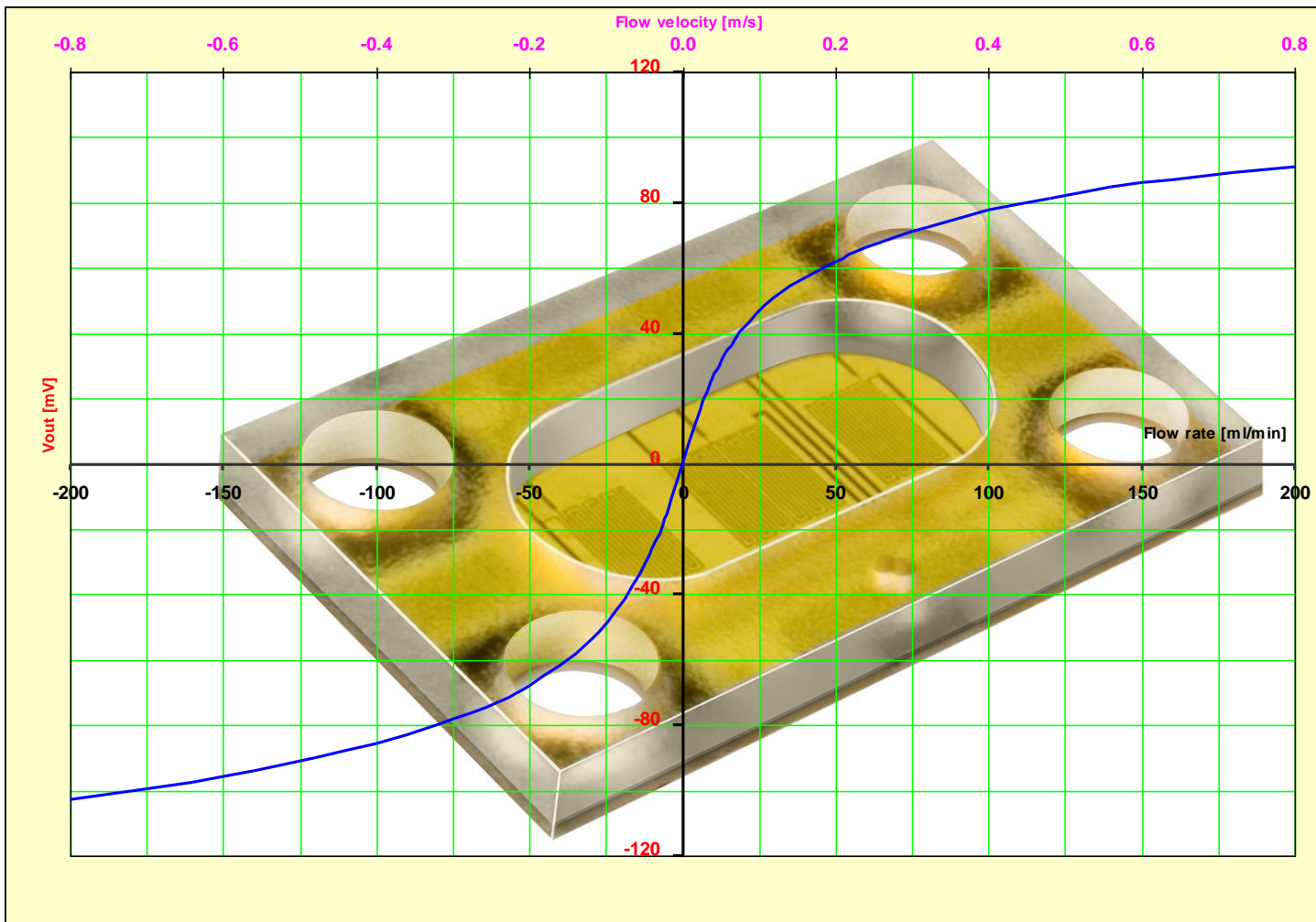



MEMS- Manufacturing process – F O T U R A N

Photo-structuring

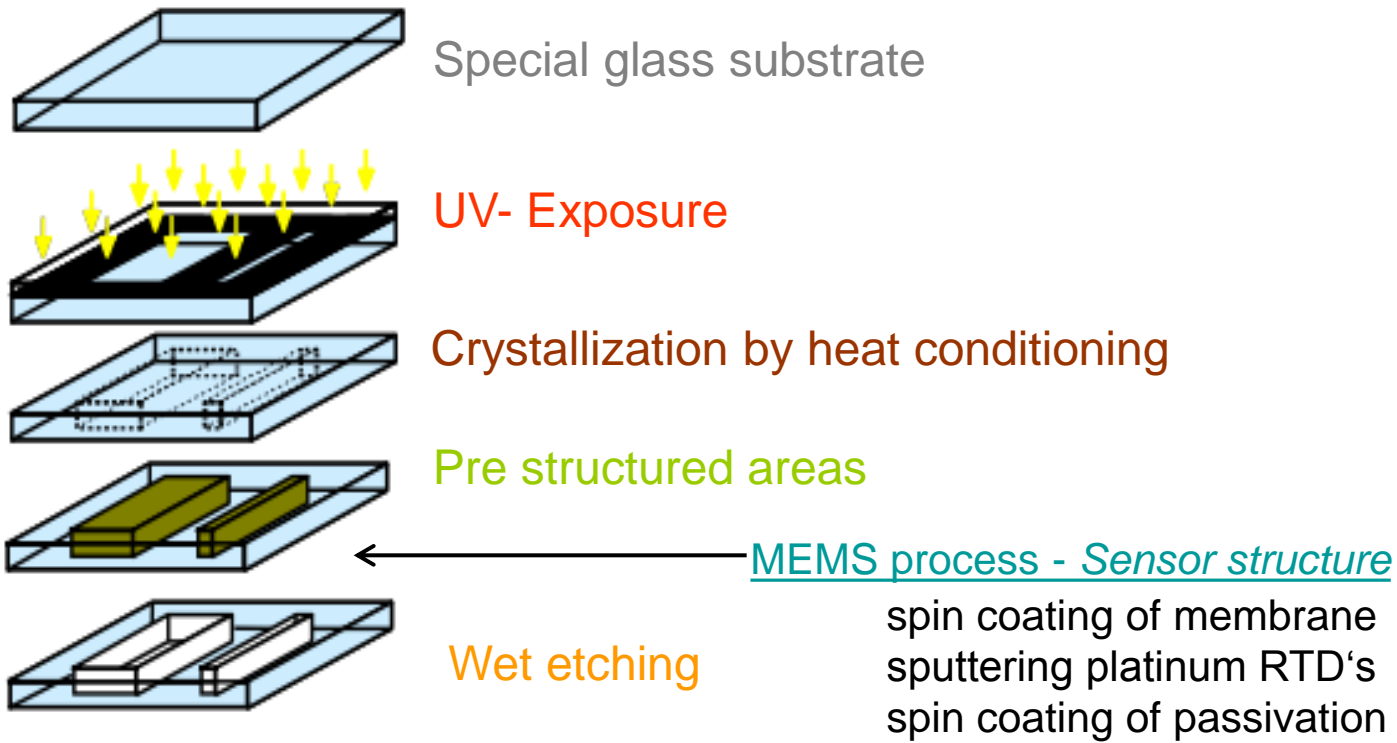

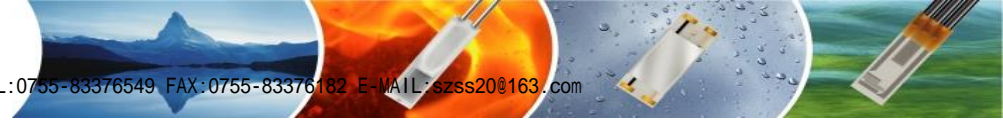

MEMS- Manufacturing process – Sensor structures



Photo structured glass substrate
with membrane - polymere dot

Spin coating prozess

Sputtering thin film platinum

Photolithographic mask process

Ion based etching process

RTD- structure passivation



Sensor application – chip layouts and circuits

- Different resistor arrangements and values depending on flow application
- Customized sensors possible because of inexpensive mask processes

1 heater, 1 Temp. sensor

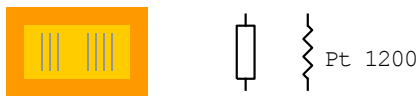

Simple resistive structure for using in CTA - mode

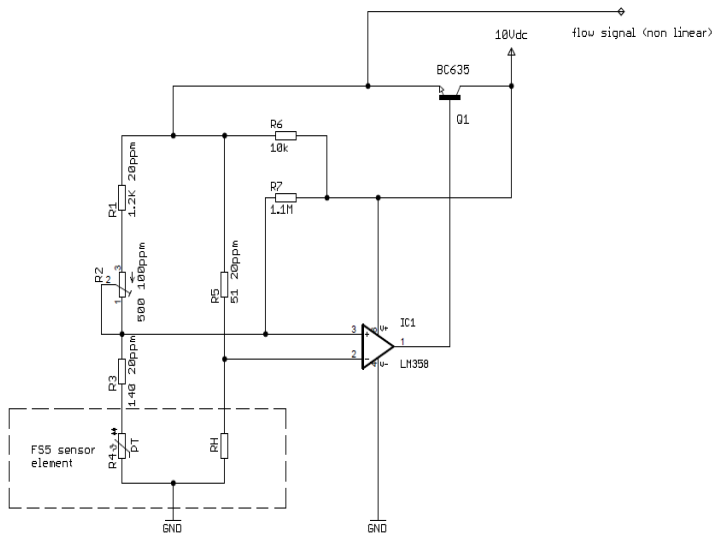

4-resistors

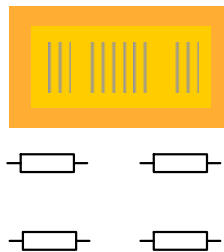

Using as full bridge with Constant voltage or current supply
 Flow direction sensitive

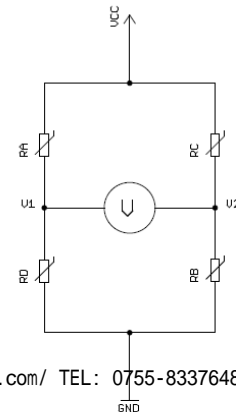

4-resistors + Temp. sensor

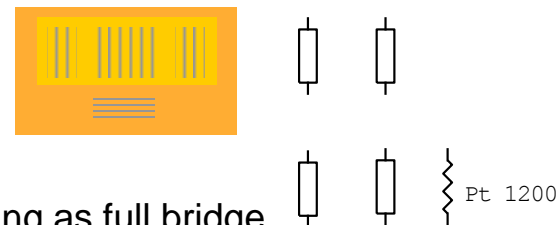

Using as full bridge in a CTA ;Flow direction sensitive

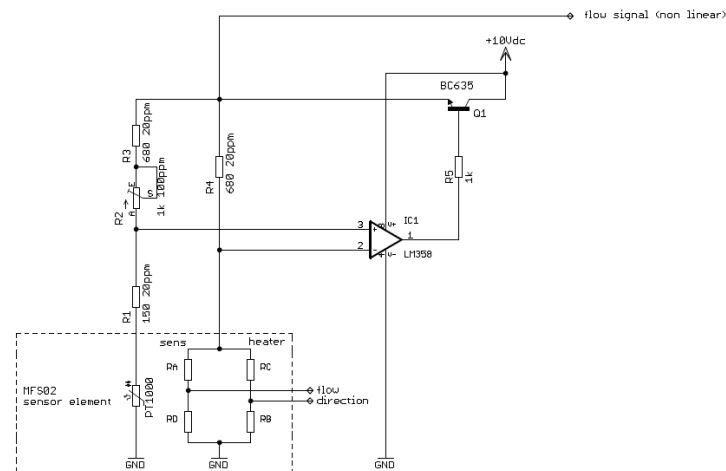

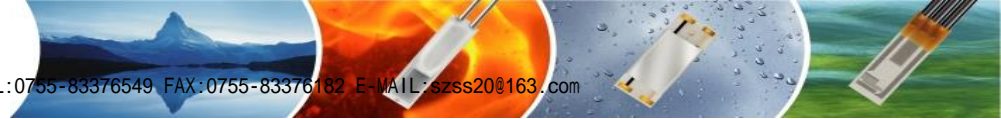

Sensor application – thermal sensor properties

Sensor surface

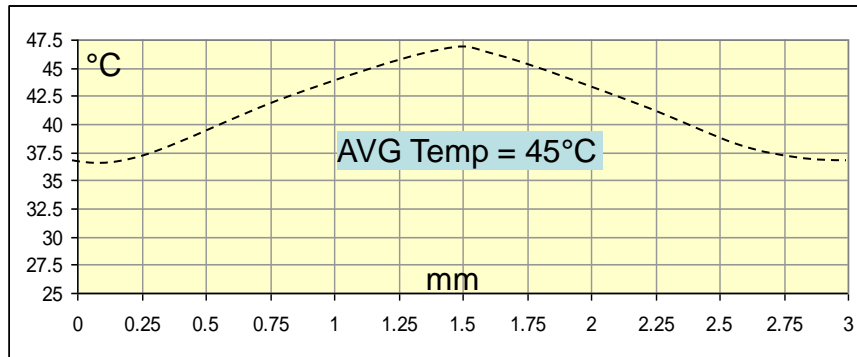

Simple full bridge calorimeter mode

Sensor supply 3mA and about 2,5 volts

Flow rate 0,00 mlN/min

Sensor surface

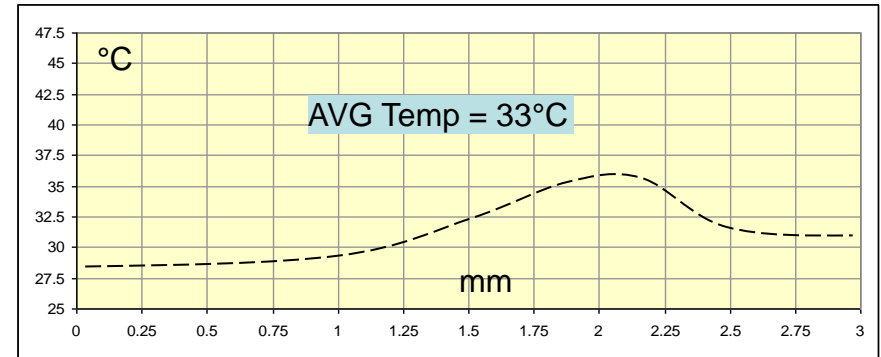

Simple full bridge calorimeter mode

Sensor supply 3mA and about 2,5 volts

Flow rate 200 mlN/min

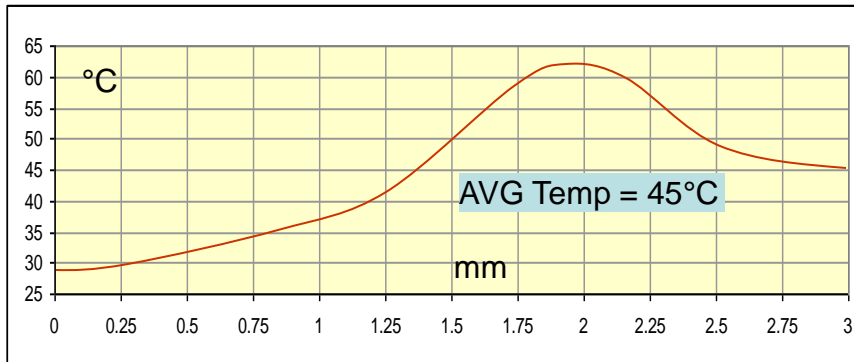

Full bridge calorimeter mode and CTA biasing

Sensor supply 4mA and about 3,5 volts

Flow rate 600 mlN/min



Sensor application – measuring properties

Low flow ranges

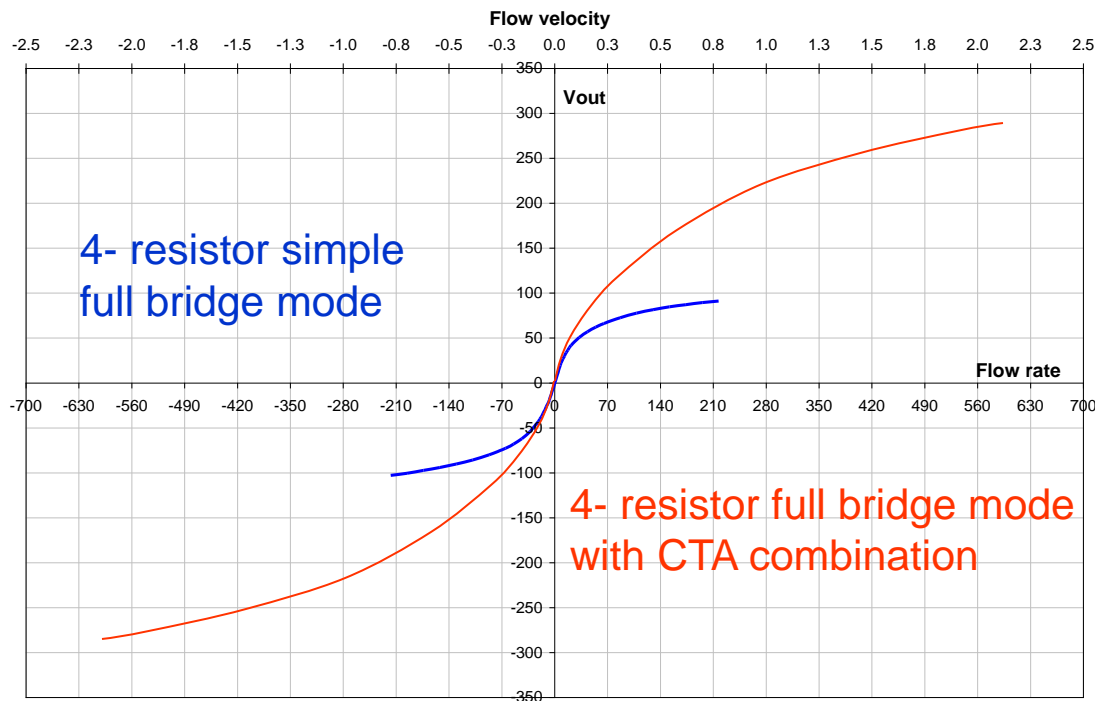

Unamplified nominal sensitivity
3mV/ mlNmin⁻¹
In zero cross point

Physical flow range enlargement
by full bridge mode with CTA biasing

No cool down effect of heater
with CTA biasing.

Heating power 10mW to 50mW

Stable zero cross point; independent on any drift effects like contamination.





Sensor application – measuring properties

High flow CTA mode- range

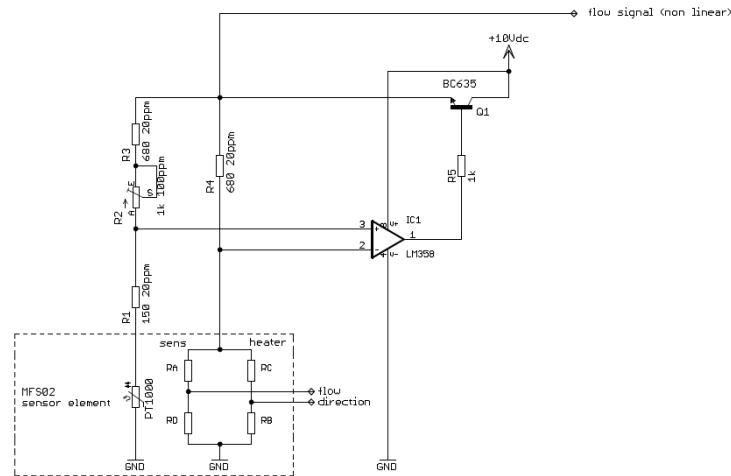
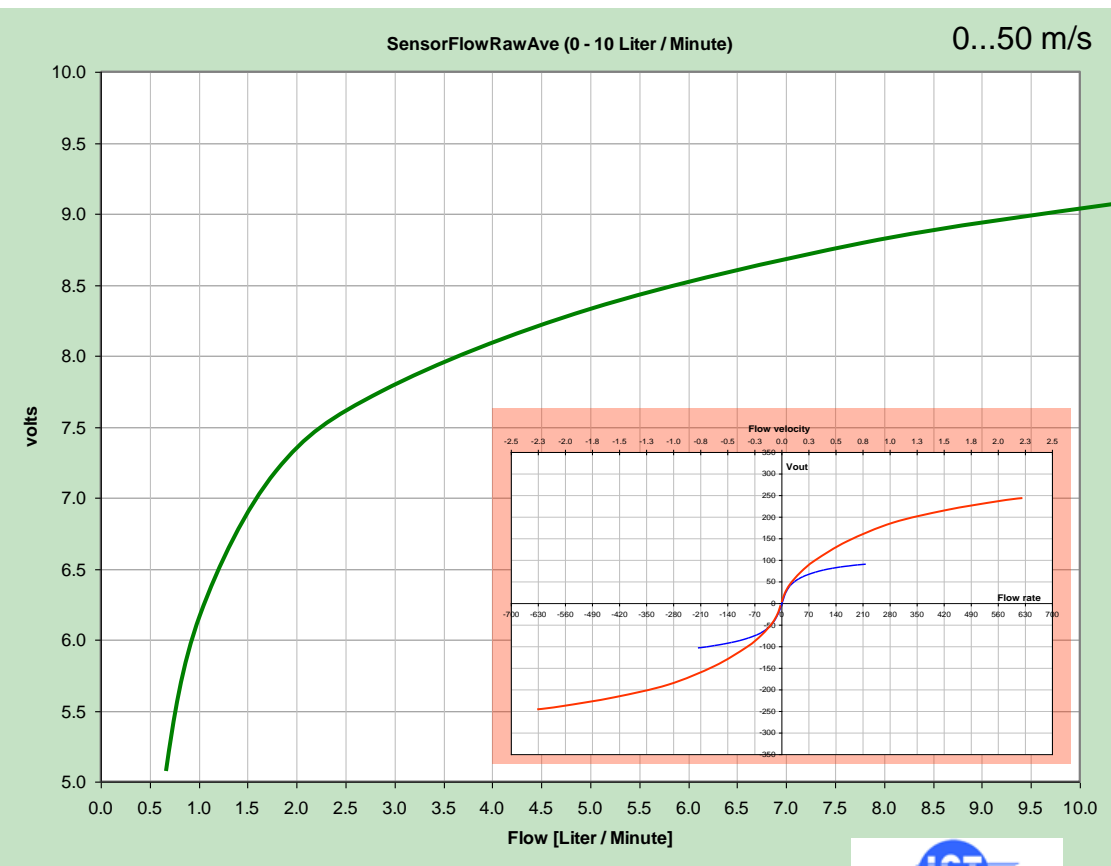

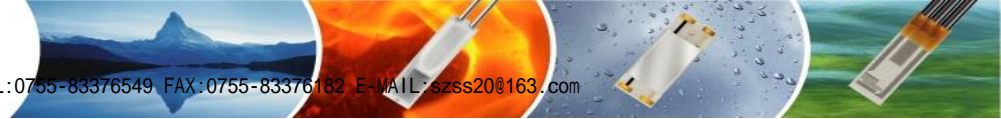

Sensor application – assembly possibilities

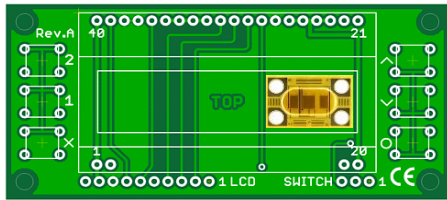

- Easy to use and robust sensor construction
- PCB integration by mounting in a cavity or hole
- Connecting by wire bonding or soldering
- Backsite mounting of flow channel

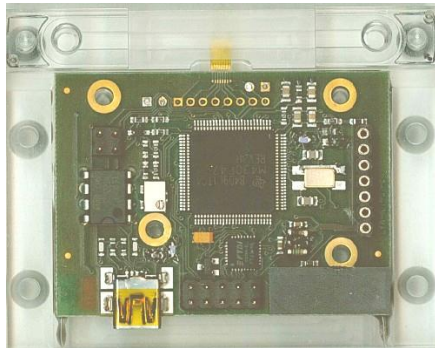

- Sensor mounted in a separate flow channel
- wire bonded flow sensor for pcb connection
- Pick & place assembling of sensor possible
- Plug and play module by USB interface

Example with the wire bonding sensor type MFS02 together with an ASIC on a pcb.

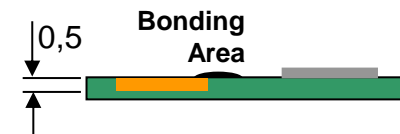
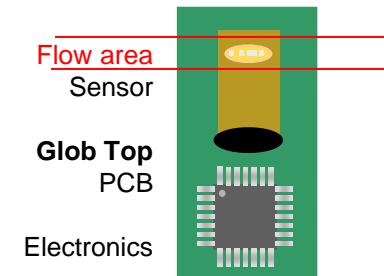



Microflow sensor – summary of behaviors MFS02

Product

Especially for fast flow measurements and wire bonding assembly, the Flow Sensor **MFS 02** was developed. Due to a membrane system the thermal mass is reduced to the minimum. Very fast response time and low power consumption are resulting from this little thermal mass. The membrane is just a few microns thick and is carried by a glass substrate. Therefore the system is robust and the device can be handled easily.

Advantages

- Fast response time
- Small mass flow rates
- Detection of flow direction
- Low power consumption
- Small thermal mass
- Robust design
- Best price-performance ratio

Applications

- Medical devices
- Home spirometers
- Differential pressure sensors
- Mikrofluidic (gas)