

# Freescale Semiconductor

MPXV5004G  
Rev 12, 09/2009

## Integrated Silicon Pressure Sensor On-Chip Signal Conditioned, Temperature Compensated and Calibrated

The MPxx5004 series piezoresistive transducer is a state-of-the-art monolithic silicon pressure sensor designed for a wide range of applications, but particularly those employing a microcontroller or microprocessor with A/D inputs. This sensor combines a highly sensitive implanted strain gauge with advanced micromachining techniques, thin-film metallization, and bipolar processing to provide an accurate, high level analog output signal that is proportional to the applied pressure.

### Features

- 1.5% Maximum Error for 0 to 100 mm H<sub>2</sub>O over +10° to +60°C with Auto Zero
- 2.5% Maximum Error for 100 to 400 mm H<sub>2</sub>O over +10° to +60°C with Auto Zero
- 6.25% Maximum Error for 0 to 400 mm H<sub>2</sub>O over +10° to +60°C without Auto Zero
- Temperature Compensated over 10° to 60°C
- Available in Gauge Surface Mount (SMT) or Through-Hole (DIP) Configurations
- Durable Thermoplastic (PPS) Package

## MPXV5004 MPVZ5004 Series

0 to 3.92 kPa  
(0 to 400 mm H<sub>2</sub>O)  
1.0 to 4.9 V Output

### Application Examples

- Washing Machine Water Level
- Ideally Suited for Microprocessor or Microcontroller-Based Systems
- Appliance Liquid Level and Pressure Measurement
- Respiratory Equipment

### ORDERING INFORMATION

Device Name	Case No.	# of Ports			Pressure Type			Device Marking
		None	Single	Dual	Gauge	Differential	Absolute	
<b>Small Outline Package (MPXV5004 Series)</b>								
MPXV5004DP	1351			•		•		MPXV5004DP
MPXV5004GC6T1	482A		•		•			MPXV5004G
MPXV5004GC6U	482A		•		•			MPXV5004G
MPXV5004GC7U	482C		•		•			MPXV5004G
MPXV5004GP	1369		•		•			MPXV5004GP
MPXV5004GPT1	1369		•		•			MPXV5004GP
MPXV5004GVP	1368		•		•			MPXV5004GVP
<b>Small Outline Package (Media Resistant Gel) (MPVZ5004 Series)</b>								
MPVZ5004G6T1	482	•			•			MPVZ5004G
MPVZ5004G6U	482	•			•			MPVZ5004G
MPVZ5004G7U	482B	•			•			MPVZ5004G
MPVZ5004GC6U	482A		•		•			MPVZ5004G
MPVZ5004GW6U	1735		•		•			MZ5004GW
MPVZ5004GW7U	1560		•		•			MZ5004GW

## SMALL OUTLINE PACKAGES THROUGH-HOLE

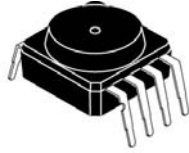

**MPVZ5004G7U**  
CASE 482B-03

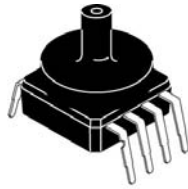

**MPXV5004GC7U**  
CASE 482C-03

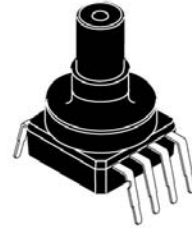

**MPVZ5004GW7U**  
CASE 1560-02

## SMALL OUTLINE PACKAGES SURFACE MOUNT

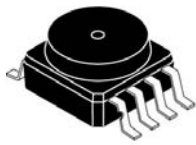

**MPVZ5004G6U/6T1**  
CASE 482-01

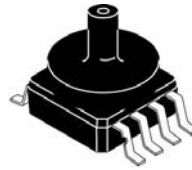

**MPXV5004G6U/6T1, MPVZ5004GC6U**  
CASE 482A-01

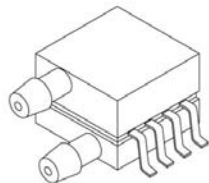

**MPXV5004DP**  
CASE 1351-01

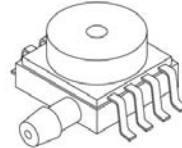

**MPXV5004GVP**  
CASE 1368-01

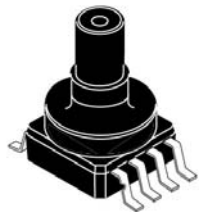

**MPVZ5004GW6U**  
CASE 1735-01

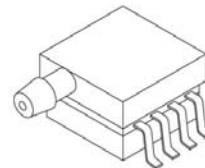

**MPXV5004GP/GPT1**  
CASE 1369-01

## MPXV5004G

## Operating Characteristics

**Table 1. Operating Characteristics** ( $V_S = 5.0 V_{DC}$ ,  $T_A = 25^\circ C$  unless otherwise noted,  $P_1 > P_2$ )

Characteristic	Symbol	Min	Typ	Max	Units	
Pressure Range	$P_{OP}$	0	—	3.92 400	kPa mm H <sub>2</sub> O	
Supply Voltage <sup>(1)</sup>	$V_S$	4.75	5.0	5.25	$V_{DC}$	
Supply Current	$I_S$	—	—	10	mAdc	
Span @ 306 mm H <sub>2</sub> O (3 kPa) <sup>(2)</sup> Full Scale Span @ 400 mm H <sub>2</sub> O (3.92 kPa) <sup>(2)</sup>	$V_{FSS}$	— —	3.0 4.0	— —	V	
Offset <sup>(3)</sup>	$V_{OFF}$	0.75	1.0	1.25	V	
Sensitivity	V/P	—	1.0	—	V/kPa	
Accuracy <sup>(4)</sup> <sup>(5)</sup>	0 to 100 mm H <sub>2</sub> O (10 to 60°C)	—	—	—	±1.5	% $V_{FSS}$ with auto zero
	100 to 400 mm H <sub>2</sub> O (10 to 60°C)	—	—	—	±2.5	% $V_{FSS}$ with auto zero
	0 to 400 mm H <sub>2</sub> O (10 to 60°C)	—	—	—	±6.25	% $V_{FSS}$ without auto zero

1. Device is ratiometric within this specified excitation range.
2. Span is defined as the algebraic difference between the output voltage at specified pressure and the output voltage at the minimum rated pressure.
3. Offset ( $V_{off}$ ) is defined as the output voltage at the minimum rated pressure.
4. Accuracy (error budget) consists of the following:
  - Linearity: Output deviation from a straight line relationship with pressure over the specified pressure range.
  - Temperature Hysteresis: Output deviation at any temperature within the operating temperature range, after the temperature is cycled to and from the minimum or maximum operating temperature points, with zero differential pressure applied.
  - Pressure Hysteresis: Output deviation at any pressure within the specified range, when this pressure is cycled to and from the minimum or maximum rated pressure, at 25°C.
  - Offset Stability: Output deviation, after 1000 temperature cycles, -30 to 100°C, and 1.5 million pressure cycles, with minimum rated pressure applied.
  - TcSpan: Output deviation over the temperature range of 10 to 60°C, relative to 25°C.
  - TcOffset: Output deviation with minimum rated pressure applied, over the temperature range of 10 to 60°C, relative to 25°C.
  - Variation from Nominal: The variation from nominal values, for Offset or Full Scale Span, as a percent of  $V_{FSS}$ , at 25°C.
5. Auto Zero at Factory Installation: Due to the sensitivity of the MPVZ5004G, external mechanical stresses and mounting position can affect the zero pressure output reading. Autozeroing is defined as storing the zero pressure output reading and subtracting this from the device's output during normal operations. Reference AN1636 for specific information. The specified accuracy assumes a maximum temperature change of ±5°C between autozero and measurement.

## Maximum Ratings

Table 2. Maximum Ratings<sup>(1)</sup>

Rating	Symbol	Value	Unit
Maximum Pressure (P1 > P2)	P <sub>MAX</sub>	16	kPa
Storage Temperature	T <sub>STG</sub>	-30 to +100	°C
Operating Temperature	T <sub>A</sub>	0 to +85	°C

1. Exposure beyond the specified limits may cause permanent damage or degradation to the device.

Figure 1 shows a block diagram of the internal circuitry integrated on a pressure sensor chip.

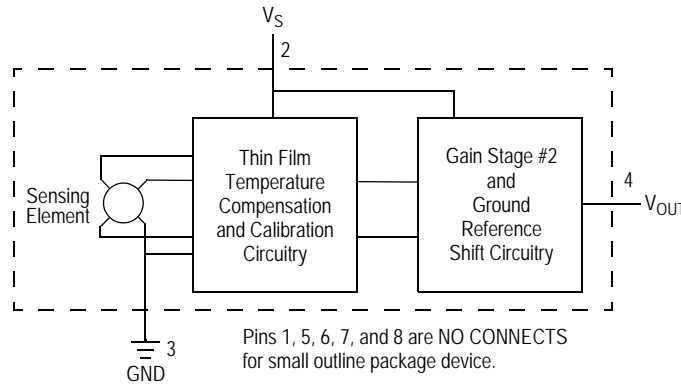

Figure 1. Integrated Pressure Sensor Schematic

## On-chip Temperature Compensation and Calibration

The performance over temperature is achieved by integrating the shear-stress strain gauge, temperature compensation, calibration and signal conditioning circuitry onto a single monolithic chip.

Figure 2 illustrates the gauge configuration in the basic chip carrier (Case 482). A fluorosilicone gel isolates the die surface and wire bonds from the environment, while allowing the pressure signal to be transmitted to the silicon diaphragm.

The MPxx5004G series sensor operating characteristics are based on use of dry air as pressure media. Media, other than dry air, may have adverse effects on sensor performance and long-term reliability. Internal reliability and

qualification test for dry air, and other media, are available from the factory. Contact the factory for information regarding media tolerance in your application.

Figure 3 shows the recommended decoupling circuit for interfacing the output of the MPxx5004G to the A/D input of the microprocessor or microcontroller. Proper decoupling of the power supply is recommended.

Typical, minimum and maximum output curves are shown for operation over a temperature range of 10°C to 60°C using the decoupling circuit shown in Figure 3. The output will saturate outside of the specified pressure range.

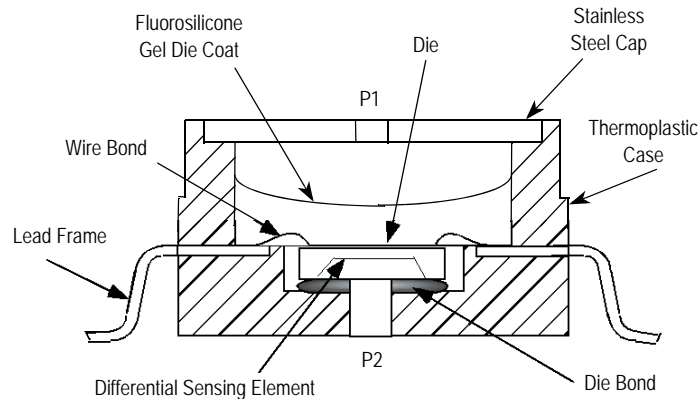
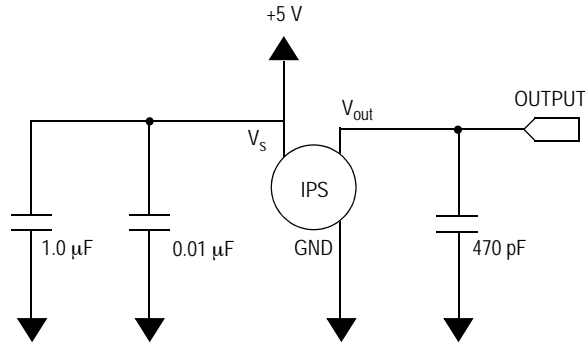
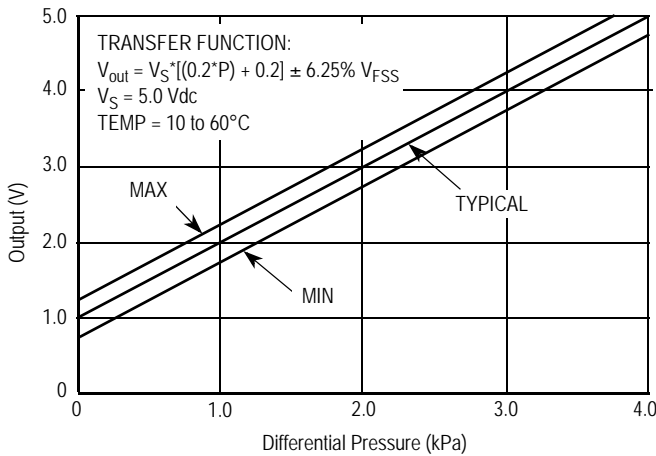

Figure 2. Cross-Sectional Diagram (Not to Scale)



**Figure 3. Recommended Power Supply Decoupling and Output Filtering**  
(For additional output filtering, please refer to AN1646.)



**Figure 4. Output vs. Pressure Differential at  $\pm 6.25\% V_{FSS}$  (without auto zero, Table 1., note 5)**

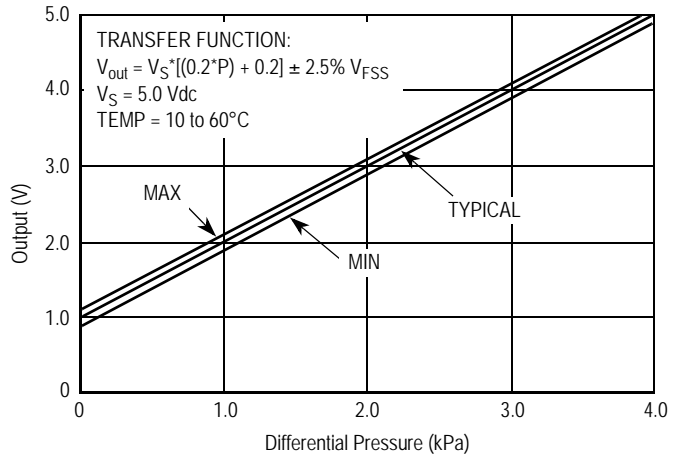

**Figure 5. Output vs. Pressure Differential at  $\pm 2.5\% V_{FSS}$  (with auto zero, Table 1., note 5))**

**PRESSURE (P1)/VACUUM (P2) SIDE IDENTIFICATION TABLE**

Freescale Semiconductor designates the two sides of the pressure sensor as the Pressure (P1) side and the Vacuum (P2) side. The Pressure (P1) side is the side containing silicone gel which isolates the die from the environment.

The Freescale Semiconductor pressure sensor is designed to operate with positive differential pressure applied, P1 > P2.

The Pressure (P1) side may be identified by using the table below.

Part Number	Case Type	Pressure (P1) Side Identifier
MPXV5004DP	1351	Side with Part Marking
MPXV5004GC6U/6T1, MPVZ5004GC6U	482A	Side with Port Attached
MPXV5004GC7U	482C	Side with Port Attached
MPXV5004GP/GPT1	1369	Side with Port Attached
MPXV5004GVP	1368	Stainless Steel Cap
MPVZ5004G6U/6T1	482	Stainless Steel Cap
MPVZ5004G7U	482B	Stainless Steel Cap
MPVZ5004GW6U	1735	Vertical Port Attached
MPVZ5004GW7U	1560	Vertical Port Attached

**INFORMATION FOR USING THE SMALL OUTLINE PACKAGE (CASE 482)****MINIMUM RECOMMENDED FOOTPRINT FOR SURFACE MOUNTED APPLICATIONS**

Surface mount board layout is a critical portion of the total design. The footprint for the surface mount packages must be the correct size to ensure proper solder connection interface

between the board and the package. With the correct footprint, the packages will self align when subjected to a solder reflow process. It is always recommended to design boards with a solder mask layer to avoid bridging and shorting between solder pads.

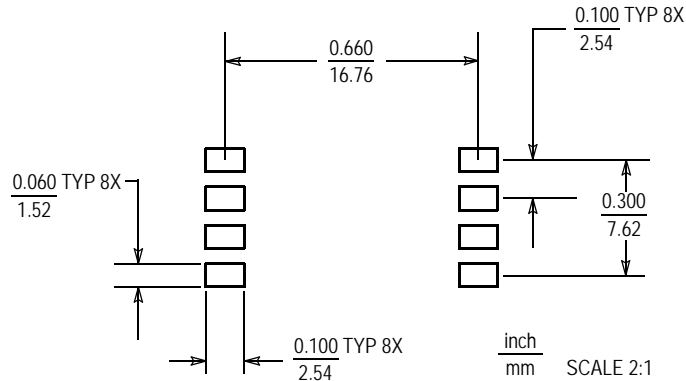

**Figure 6. SOP Footprint (Case 482)**

### PACKAGE DIMENSIONS

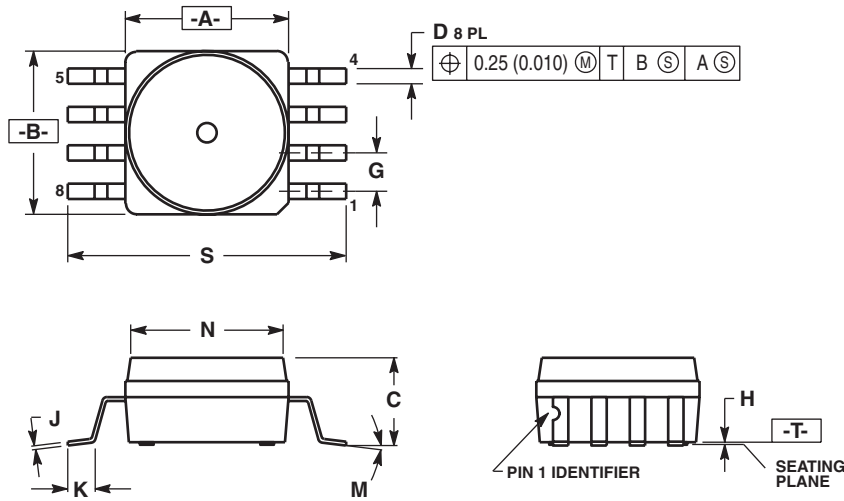

- NOTES:
1. DIMENSIONING AND TOLERANCING PER ANSI Y14.5M, 1982.
  2. CONTROLLING DIMENSION: INCH.
  3. DIMENSION A AND B DO NOT INCLUDE MOLD PROTRUSION.
  4. MAXIMUM MOLD PROTRUSION 0.15 (0.006).
  5. ALL VERTICAL SURFACES 5° TYPICAL DRAFT.

DIM	INCHES		MILLIMETERS	
	MIN	MAX	MIN	MAX
A	0.415	0.425	10.54	10.79
B	0.415	0.425	10.54	10.79
C	0.212	0.230	5.38	5.84
D	0.038	0.042	0.96	1.07
G	0.100 BSC		2.54 BSC	
H	0.002	0.010	0.05	0.25
J	0.009	0.011	0.23	0.28
K	0.061	0.071	1.55	1.80
M	0"	7"	0"	7"
N	0.405	0.415	10.29	10.54
S	0.709	0.725	18.01	18.41

**CASE 482-01  
ISSUE O  
SMALL OUTLINE PACKAGE  
SURFACE MOUNT**

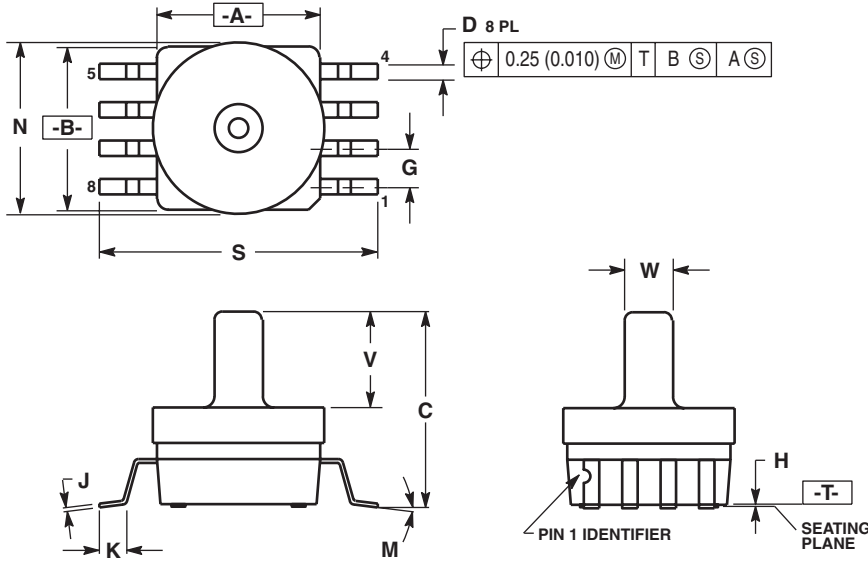

- NOTES:
1. DIMENSIONING AND TOLERANCING PER ANSI Y14.5M, 1982.
  2. CONTROLLING DIMENSION: INCH.
  3. DIMENSION A AND B DO NOT INCLUDE MOLD PROTRUSION.
  4. MAXIMUM MOLD PROTRUSION 0.15 (0.006).
  5. ALL VERTICAL SURFACES 5° TYPICAL DRAFT.

DIM	INCHES		MILLIMETERS	
	MIN	MAX	MIN	MAX
A	0.415	0.425	10.54	10.79
B	0.415	0.425	10.54	10.79
C	0.500	0.520	12.70	13.21
D	0.038	0.042	0.96	1.07
G	0.100 BSC		2.54 BSC	
H	0.002	0.010	0.05	0.25
J	0.009	0.011	0.23	0.28
K	0.061	0.071	1.55	1.80
M	0"	7"	0"	7"
N	0.444	0.448	11.28	11.38
S	0.709	0.725	18.01	18.41
V	0.245	0.255	6.22	6.48
W	0.115	0.125	2.92	3.17

**CASE 482A-01  
ISSUE A  
SMALL OUTLINE PACKAGE  
SURFACE MOUNT**

### PACKAGE DIMENSIONS

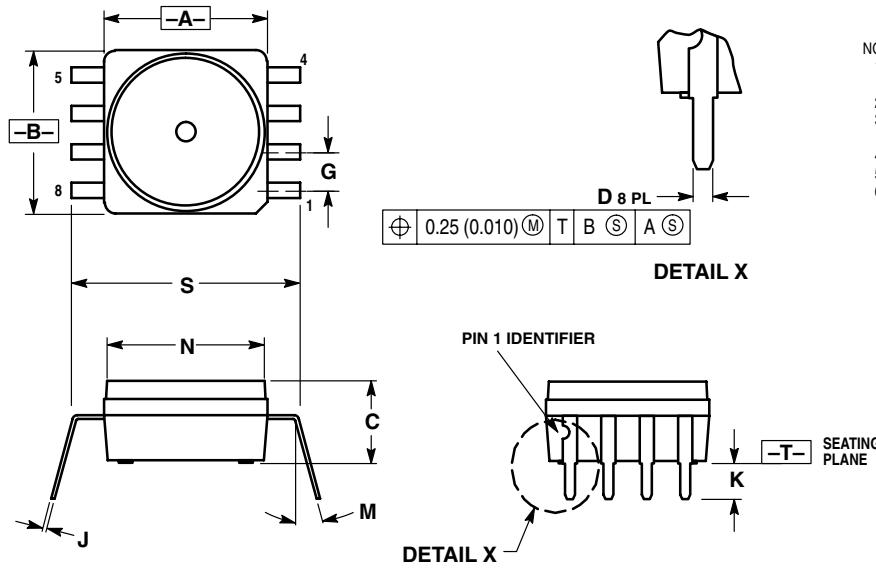

- NOTES:
1. DIMENSIONING AND TOLERANCING PER ANSI Y14.5M, 1982.
  2. CONTROLLING DIMENSION: INCH.
  3. DIMENSION A AND B DO NOT INCLUDE MOLD PROTRUSION.
  4. MAXIMUM MOLD PROTRUSION 0.15 (0.006).
  5. ALL VERTICAL SURFACES 5° TYPICAL DRAFT.
  6. DIMENSION S TO CENTER OF LEAD WHEN FORMED PARALLEL.

DIM	INCHES		MILLIMETERS	
	MIN	MAX	MIN	MAX
A	0.415	0.425	10.54	10.79
B	0.415	0.425	10.54	10.79
C	0.210	0.220	5.33	5.59
D	0.026	0.034	0.66	0.864
G	0.100 BSC		2.54 BSC	
J	0.009	0.011	0.23	0.28
K	0.100	0.120	2.54	3.05
M	0°	15°	0°	15°
N	0.405	0.415	10.29	10.54
S	0.540	0.560	13.72	14.22

**CASE 482B-03  
ISSUE B  
SMALL OUTLINE PACKAGE  
THROUGH-HOLE**

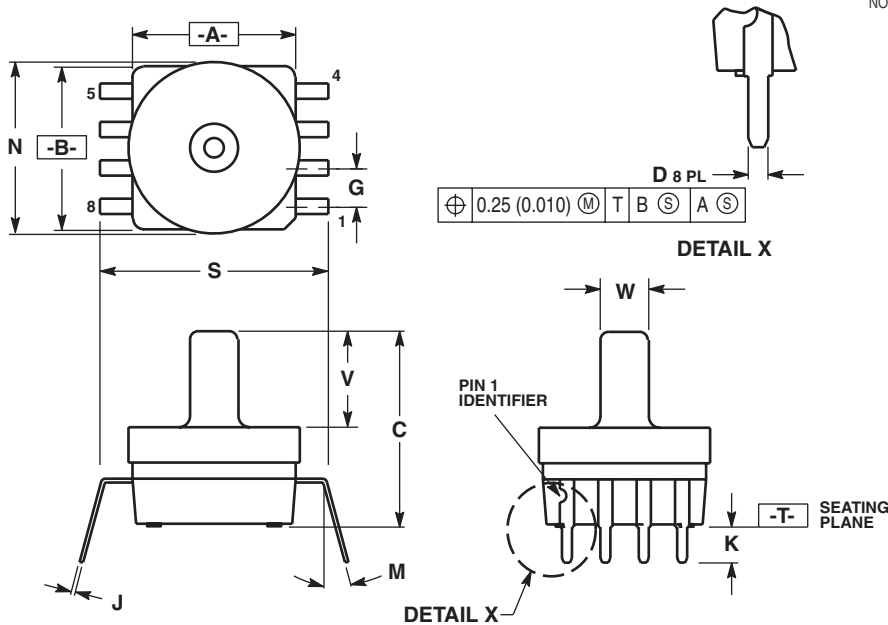

- NOTES:
1. DIMENSIONING AND TOLERANCING PER ANSI Y14.5M, 1982.
  2. CONTROLLING DIMENSION: INCH.
  3. DIMENSION A AND B DO NOT INCLUDE MOLD PROTRUSION.
  4. MAXIMUM MOLD PROTRUSION 0.15 (0.006).
  5. ALL VERTICAL SURFACES 5° TYPICAL DRAFT.
  6. DIMENSION S TO CENTER OF LEAD WHEN FORMED PARALLEL.

DIM	INCHES		MILLIMETERS	
	MIN	MAX	MIN	MAX
A	0.415	0.425	10.54	10.79
B	0.415	0.425	10.54	10.79
C	0.500	0.520	12.70	13.21
D	0.026	0.034	0.66	0.864
G	0.100 BSC		2.54 BSC	
J	0.009	0.011	0.23	0.28
K	0.100	0.120	2.54	3.05
M	0°	15°	0°	15°
N	0.444	0.448	11.28	11.38
S	0.540	0.560	13.72	14.22
V	0.245	0.255	6.22	6.48
W	0.115	0.125	2.92	3.17

**CASE 482C-03  
ISSUE B  
SMALL OUTLINE PACKAGE  
THROUGH-HOLE**



### PACKAGE DIMENSIONS

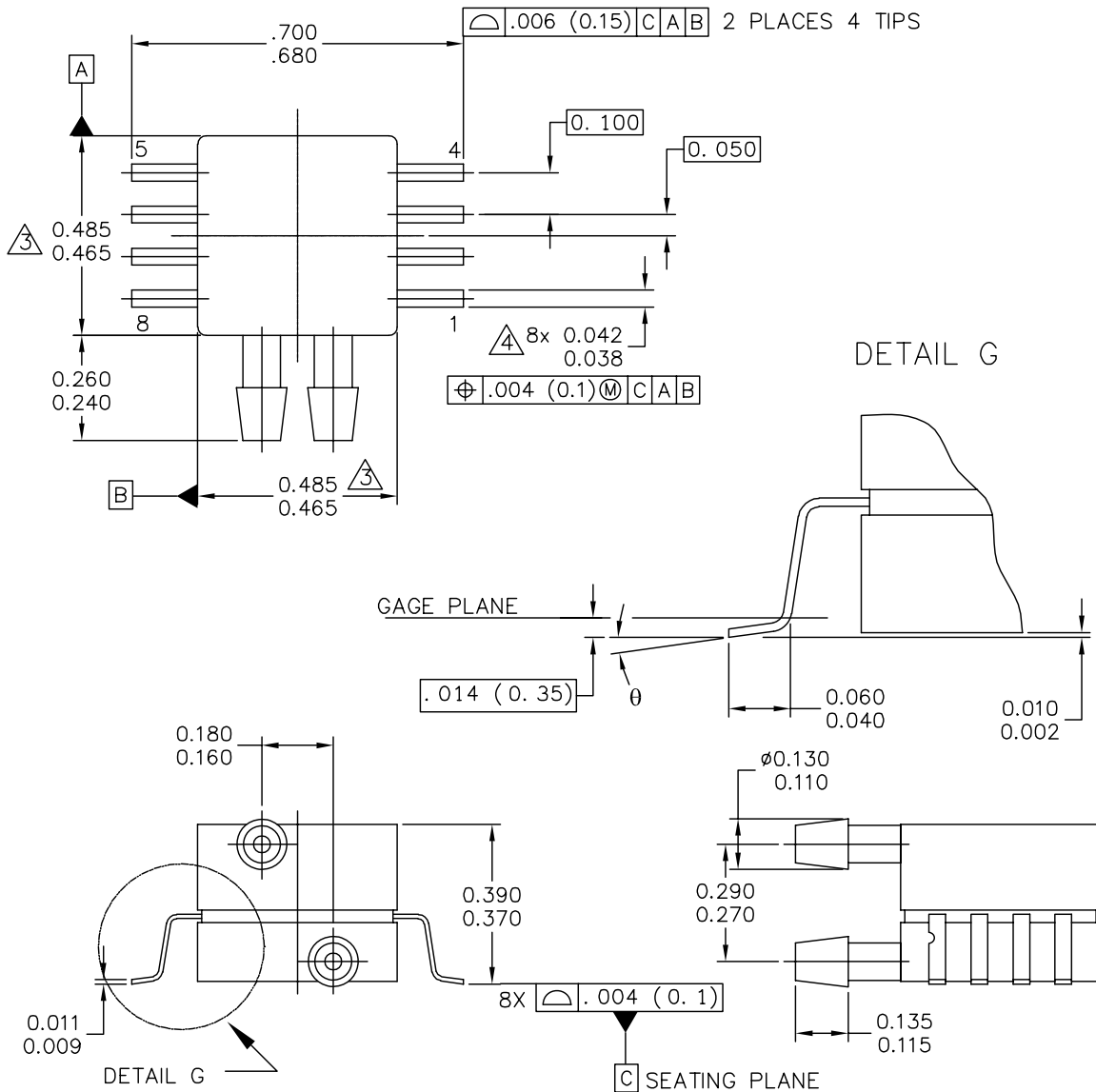

© FREESCALE SEMICONDUCTOR, INC. ALL RIGHTS RESERVED.	<b>MECHANICAL OUTLINE</b>	PRINT VERSION NOT TO SCALE
TITLE:  8 LD SNSR, DUAL PORT	DOCUMENT NO: 98ASA99255D	REV: A
	CASE NUMBER: 1351-01	27 JUL 2005
	STANDARD: NON-JEDEC	

**CASE 1351-01  
ISSUE A  
SMALL OUTLINE PACKAGE  
SURFACE MOUNT**

**PACKAGE DIMENSIONS**

## NOTES:

1. CONTROLLING DIMENSION: INCH

2. INTERPRET DIMENSIONS AND TOLERANCES PER ASME Y14.5M-1994.

3. DIMENSIONS DO NOT INCLUDE MOLD FLASH OR PROTRUSIONS.  
MOLD FLASH AND PROTRUSIONS SHALL NOT EXCEED .006 PER SIDE.

4. DIMENSION DOES NOT INCLUDE DAMBAR PROTRUSION. ALLOWABLE DAMBAR  
PROTRUSION SHALL BE .008 MAXIMUM.

## STYLE 1:

PIN 1: GND  
PIN 2: +Vout  
PIN 3: Vs  
PIN 4: -Vout  
PIN 5: N/C  
PIN 6: N/C  
PIN 7: N/C  
PIN 8: N/C

## STYLE 2:

PIN 1: N/C  
PIN 2: Vs  
PIN 3: GND  
PIN 4: Vout  
PIN 5: N/C  
PIN 6: N/C  
PIN 7: N/C  
PIN 8: N/C

© FREESCALE SEMICONDUCTOR, INC. ALL RIGHTS RESERVED.	<b>MECHANICAL OUTLINE</b>	PRINT VERSION NOT TO SCALE	
TITLE:  8 LD SNSR, DUAL PORT	DOCUMENT NO: 98ASA99255D		REV: A
	CASE NUMBER: 1351-01		27 JUL 2005
	STANDARD: NON-JEDEC		

PAGE 2 OF 2

**CASE 1351-01  
ISSUE A  
SMALL OUTLINE PACKAGE  
SURFACE MOUNT**

**MPXV5004G**

### PACKAGE DIMENSIONS

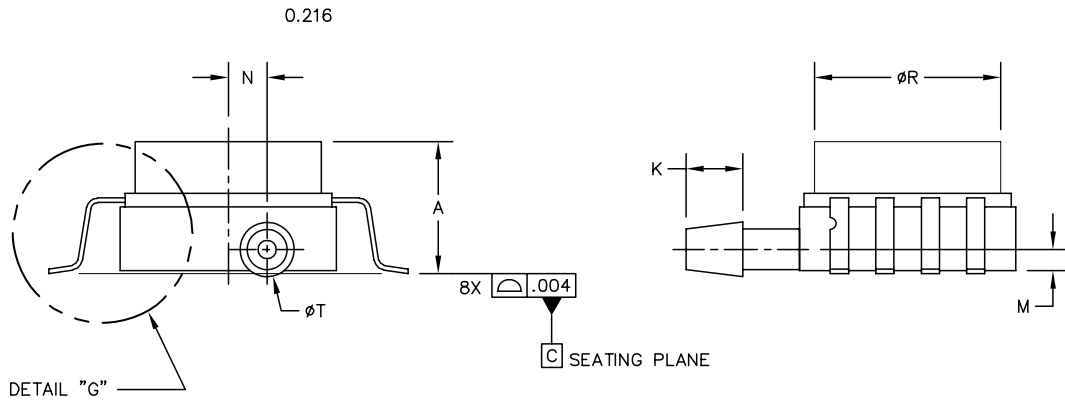
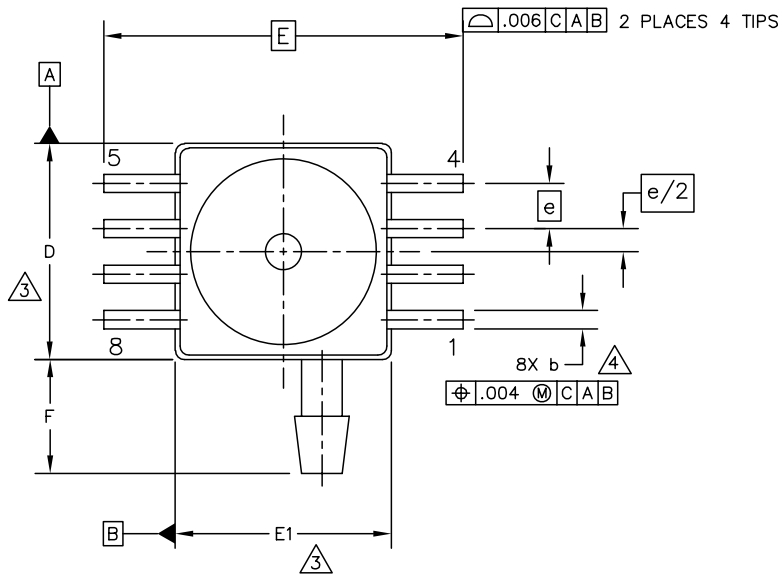

© FREESCALE SEMICONDUCTOR, INC. ALL RIGHTS RESERVED.	<b>MECHANICAL OUTLINE</b>	PRINT VERSION NOT TO SCALE	
TITLE: 8 LD SOP, GVP	DOCUMENT NO: 98ASA99302D	REV: B	
	CASE NUMBER: 1368-01	23 MAY 2005	
	STANDARD: NON-JEDEC		

PAGE 1 OF 3

**CASE 1368-01  
ISSUE B  
SMALL OUTLINE PACKAGE  
SURFACE MOUNT**

**MPXV5004G**

**PACKAGE DIMENSIONS**

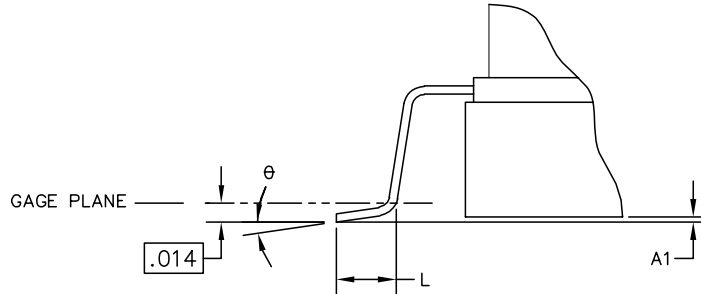

DETAIL "G"

© FREESCALE SEMICONDUCTOR, INC. ALL RIGHTS RESERVED.	<b>MECHANICAL OUTLINE</b>	PRINT VERSION NOT TO SCALE	
TITLE:  8 LD SOP, GVP	DOCUMENT NO: 98ASA99302D	REV: B	
	CASE NUMBER: 1368-01	23 MAY 2005	
	STANDARD: NON-JEDEC		

**CASE 1368-01  
ISSUE B  
SMALL OUTLINE PACKAGE  
SURFACE MOUNT**

## PACKAGE DIMENSIONS

NOTES:

1. CONTROLLING DIMENSION: INCH
2. INTERPRET DIMENSIONS AND TOLERANCES PER ASME Y14.5M-1994.
3. THIS DIMENSIONS DOES NOT INCLUDE MOLD FLASH OR PROTRUSIONS. MOLD FLASH AND PROTRUSIONS SHALL NOT EXCEED .006 PER SIDE.
4. THIS DIMENSION DOES NOT INCLUDE DAMBAR PROTRUSION. ALLOWABLE DAMBAR PROTRUSION SHALL BE .008 MAXIMUM.

STYLE 1:	STYLE 2:
PIN 1: GND	PIN 1: N/C
PIN 2: +Vout	PIN 2: Vs
PIN 3: Vs	PIN 3: GND
PIN 4: -Vout	PIN 4: Vout
PIN 5: N/C	PIN 5: N/C
PIN 6: N/C	PIN 6: N/C
PIN 7: N/C	PIN 7: N/C
PIN 8: N/C	PIN 8: N/C

DIM	INCHES		MILLIMETERS		DIM	INCHES		MILLIMETERS	
	MIN	MAX	MIN	MAX		MIN	MAX	MIN	MAX
A	.280	.300	7.11	7.62	R	.405	.415	10.28	10.54
A1	.002	.010	0.05	0.25	θ	0°	7°	0°	7°
b	.038	.042	0.96	1.07	-	---	---	---	---
D	.465	.485	11.81	12.32	-	---	---	---	---
E	.690 BSC		17.52 BSC		-	---	---	---	---
E1	.465	.485	11.85	12.32	-	---	---	---	---
e	.100 BSC		2.54 BSC		-	---	---	---	---
F	.240	.260	6.10	6.60	-	---	---	---	---
K	.115	.135	2.92	3.43	-	---	---	---	---
L	.040	.060	1.02	1.52	-	---	---	---	---
M	.035	.055	1.90	2.41	-	---	---	---	---
N	.075	.095	0.89	1.39	-	---	---	---	---
P	.009	.011	0.23	0.28	-	---	---	---	---
T	.110	.130	2.79	3.30	-	---	---	---	---

© FREESCALE SEMICONDUCTOR, INC. ALL RIGHTS RESERVED.	<b>MECHANICAL OUTLINE</b>	PRINT VERSION NOT TO SCALE	
TITLE: 8 LD SOP, GVP		DOCUMENT NO: 98ASA99302D	REV: B
		CASE NUMBER: 1368-01	23 MAY 2005
STANDARD: NON-JEDEC			

PAGE 3 OF 3

**CASE 1368-01  
ISSUE B  
SMALL OUTLINE PACKAGE  
SURFACE MOUNT**

**MPXV5004G**

**PACKAGE DIMENSIONS**

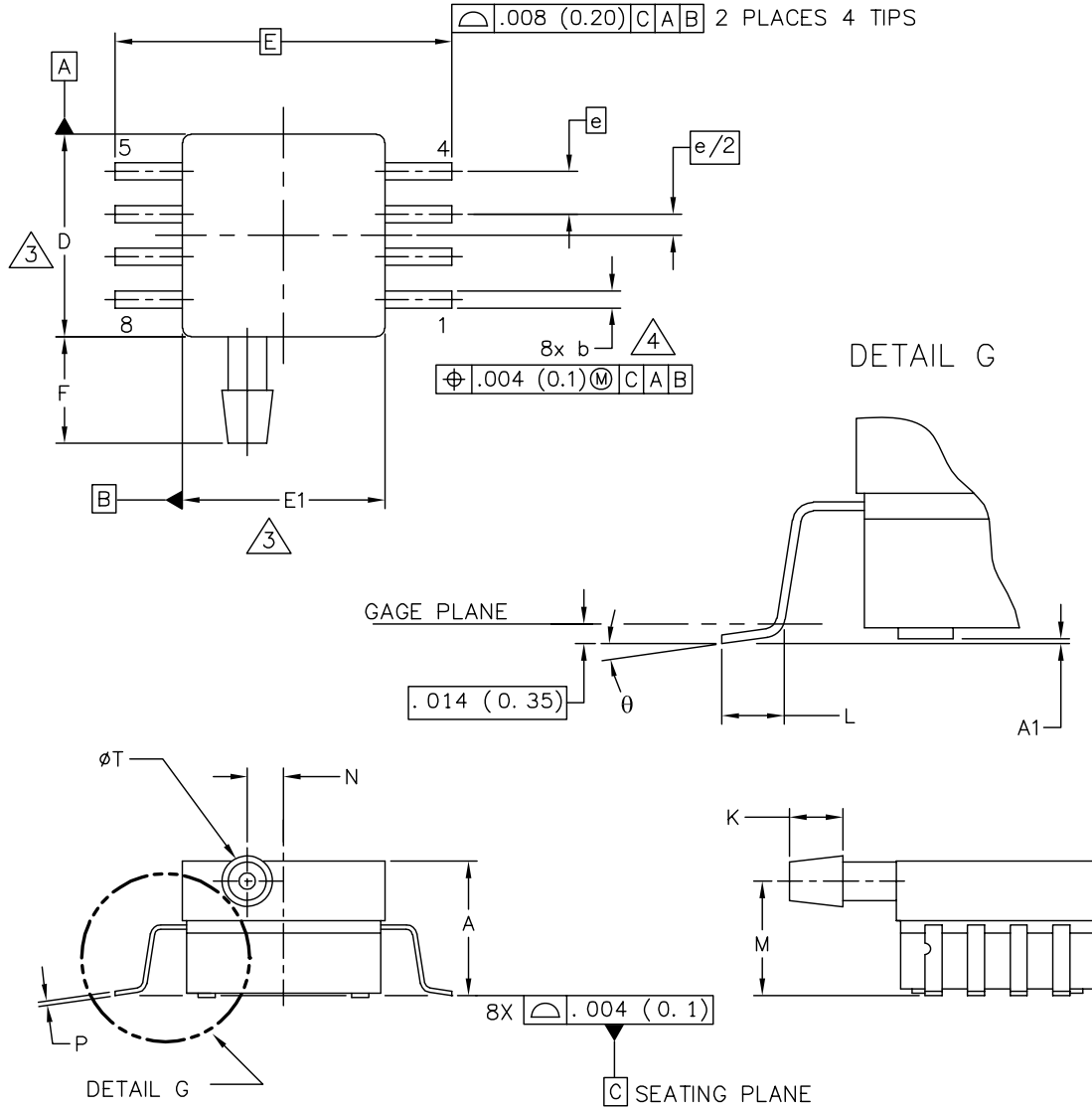

© FREESCALE SEMICONDUCTOR, INC. ALL RIGHTS RESERVED.	<b>MECHANICAL OUTLINE</b>	PRINT VERSION NOT TO SCALE
TITLE:  8 LD SOP, SIDE PORT	DOCUMENT NO: 98ASA99303D	REV: B
	CASE NUMBER: 1369-01	24 MAY 2005
	STANDARD: NON-JEDEC	

**CASE 1369-01  
ISSUE B  
SMALL OUTLINE PACKAGE**

### PACKAGE DIMENSIONS

NOTES:

1. CONTROLLING DIMENSION: INCH
2. INTERPRET DIMENSIONS AND TOLERANCES PER ASME Y14.5M-1994.
- ③ DIMENSIONS DO NOT INCLUDE MOLD FLASH OR PROTRUSIONS.  
MOLD FLASH AND PROTRUSIONS SHALL NOT EXCEED .006 (0.152) PER SIDE.
- ④ DIMENSION DOES NOT INCLUDE DAMBAR PROTRUSION. ALLOWABLE DAMBAR PROTRUSION SHALL BE .008 (0.203) MAXIMUM.

DIM	INCHES		MILLIMETERS		DIM	INCHES		MILLIMETERS	
	MIN	MAX	MIN	MAX		MIN	MAX	MIN	MAX
A	.300	.330	7.11	7.62	θ	0°	7°	0°	7°
A1	.002	.010	0.05	0.25	-	---	---	---	---
b	.038	.042	0.96	1.07	-	---	---	---	---
D	.465	.485	11.81	12.32	-	---	---	---	---
E	.717 BSC		18.21 BSC		-	---	---	---	---
E1	.465	.485	11.81	12.32	-	---	---	---	---
e	.100 BSC		2.54 BSC		-	---	---	---	---
F	.245	.255	6.22	6.47	-	---	---	---	---
K	.120	.130	3.05	3.30	-	---	---	---	---
L	.061	.071	1.55	1.80	-	---	---	---	---
M	.270	.290	6.86	7.36	-	---	---	---	---
N	.080	.090	2.03	2.28	-	---	---	---	---
P	.009	.011	0.23	0.28	-	---	---	---	---
T	.115	.125	2.92	3.17	-	---	---	---	---
© FREESCALE SEMICONDUCTOR, INC. ALL RIGHTS RESERVED.			<b>MECHANICAL OUTLINE</b>			PRINT VERSION NOT TO SCALE			
TITLE:  8 LD SOP, SIDE PORT					DOCUMENT NO: 98ASA99303D			REV: B	
					CASE NUMBER: 1369-01			24 MAY 2005	
					STANDARD: NON-JEDEC				

**CASE 1369-01  
ISSUE B  
SMALL OUTLINE PACKAGE**

### PACKAGE DIMENSIONS

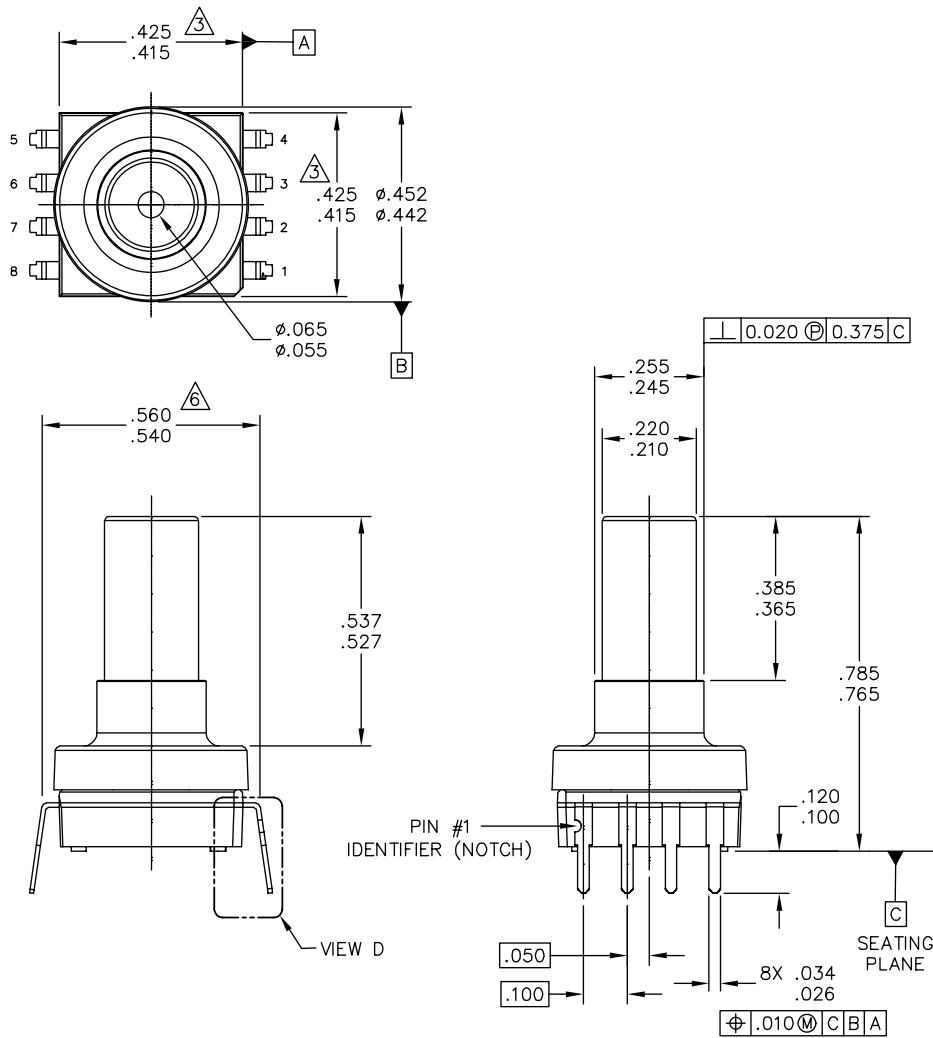

© FREESCALE SEMICONDUCTOR, INC. ALL RIGHTS RESERVED.	<b>MECHANICAL OUTLINE</b>	PRINT VERSION NOT TO SCALE	
TITLE: SO, 8 I/O, .420 X .420 PKG, .100 IN PITCH	DOCUMENT NO: 98ASA10611D	REV: D	
	CASE NUMBER: 1560-03	25 FEB 2009	
	STANDARD: NON-JEDEC		

**1560-03  
ISSUE C  
SMALL OUTLINE PACKAGE**



### PACKAGE DIMENSIONS

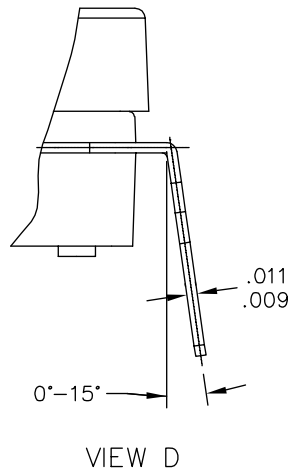

© FREESCALE SEMICONDUCTOR, INC. ALL RIGHTS RESERVED.	<b>MECHANICAL OUTLINE</b>	PRINT VERSION NOT TO SCALE	
TITLE: SO, 8 I/O, .420 X .420 PKG, .100 IN PITCH	DOCUMENT NO: 98ASA10611D	REV: D	
	CASE NUMBER: 1560-03	25 FEB 2009	
	STANDARD: NON-JEDEC		

PAGE 2 OF 3

**CASE 1560-03  
ISSUE D  
SMALL OUTLINE PACKAGE**

**MPXV5004G**

**PACKAGE DIMENSIONS**

## NOTES:

1. DIMENSIONING AND TOLERANCING PER ASME Y14.5M – 1994.
2. CONTROLLING DIMENSION: INCH.
3. DIMENSIONS DO NOT INCLUDE MOLD PROTRUSION.
4. MAXIMUM MOLD PROTRUSION IS .006.
5. ALL VERTICAL SURFACES 5° TYPICAL DRAFT.
6. DIMENSION TO CENTER OF LEAD WHEN FORMED PARALLEL.

© FREESCALE SEMICONDUCTOR, INC. ALL RIGHTS RESERVED.	<b>MECHANICAL OUTLINE</b>	PRINT VERSION NOT TO SCALE	
TITLE: SO, 8 I/O, .420 X .420 PKG, .100 IN PITCH	DOCUMENT NO: 98ASA10611D	REV: D	
	CASE NUMBER: 1560-03	25 FEB 2009	
	STANDARD: NON-JEDEC		

PAGE 3 OF 3

**CASE 1560-03  
ISSUE D  
SMALL OUTLINE PACKAGE**

### PACKAGE DIMENSIONS

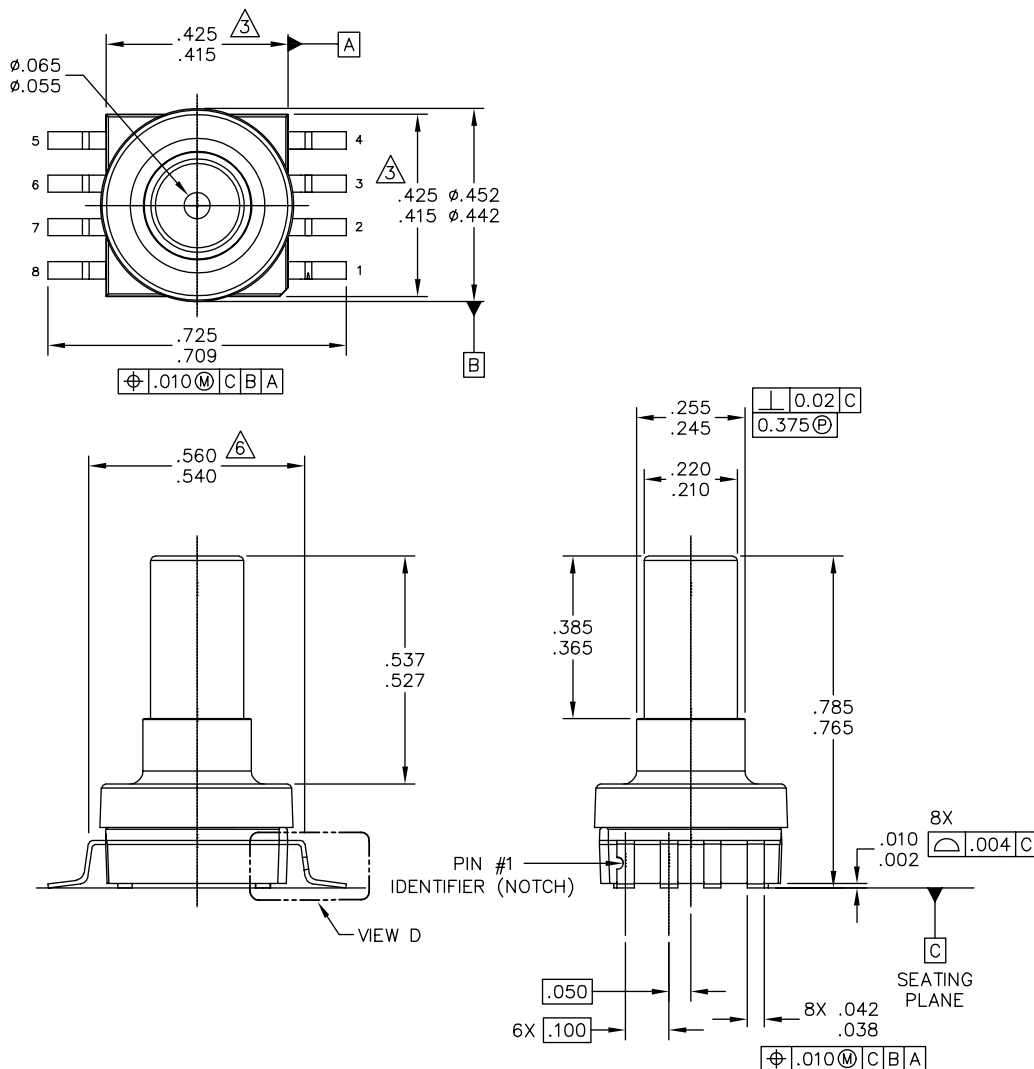

© FREESCALE SEMICONDUCTOR, INC. ALL RIGHTS RESERVED.	<b>MECHANICAL OUTLINE</b>	PRINT VERSION NOT TO SCALE
TITLE: SO, 8 I/O, .420 X .420 PKG, .100 IN PITCH	DOCUMENT NO: 98ASA10686D	REV: B
	CASE NUMBER: 1735-02	19 FEB 2009
	STANDARD: NON-JEDEC	

**CASE 1735-02  
 ISSUE B  
 SMALL OUTLINE PACKAGE**

**PACKAGE DIMENSIONS**

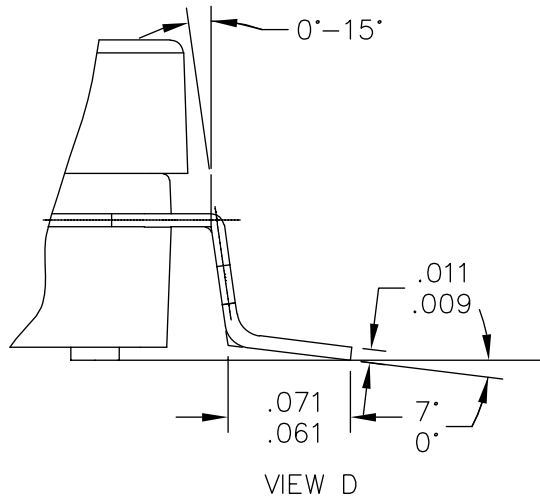

© FREESCALE SEMICONDUCTOR, INC. ALL RIGHTS RESERVED.	<b>MECHANICAL OUTLINE</b>	PRINT VERSION NOT TO SCALE	
TITLE: SO, 8 I/O, .420 X .420 PKG, .100 IN PITCH	DOCUMENT NO: 98ASA10686D	REV: B	
	CASE NUMBER: 1735-02	19 FEB 2009	
	STANDARD: NON-JEDEC		

**CASE 1735-02  
ISSUE B  
SMALL OUTLINE PACKAGE**

## PACKAGE DIMENSIONS

NOTES:

1. DIMENSIONING AND TOLERANCING PER ASME Y14.5M – 1994.
2. CONTROLLING DIMENSION: INCH.
3. DIMENSIONS DO NOT INCLUDE MOLD PROTRUSION.
4. MAXIMUM MOLD PROTRUSION IS .006.
5. ALL VERTICAL SURFACES 5° TYPICAL DRAFT.
6. DIMENSION TO CENTER OF LEAD WHEN FORMED PARALLEL.

© FREESCALE SEMICONDUCTOR, INC. ALL RIGHTS RESERVED.	<b>MECHANICAL OUTLINE</b>	PRINT VERSION NOT TO SCALE	
TITLE:  SO, 8 I/O, .420 X .420 PKG, .100 IN PITCH	DOCUMENT NO: 98ASA10686D	REV: B	
	CASE NUMBER: 1735-02	19 FEB 2009	
	STANDARD: NON-JEDEC		

PAGE 3 OF 3

**CASE 1735-02  
ISSUE B  
SMALL OUTLINE PACKAGE**

**MPXV5004G**

## How to Reach Us:

### Home Page:

[www.freescale.com](http://www.freescale.com)

### Web Support:

<http://www.freescale.com/support>

### USA/Europe or Locations Not Listed:

Freescale Semiconductor, Inc.  
Technical Information Center, EL516  
2100 East Elliot Road  
Tempe, Arizona 85284  
1-800-521-6274 or +1-480-768-2130  
[www.freescale.com/support](http://www.freescale.com/support)

### Europe, Middle East, and Africa:

Freescale Halbleiter Deutschland GmbH  
Technical Information Center  
Schatzbogen 7  
81829 Muenchen, Germany  
+44 1296 380 456 (English)  
+46 8 52200080 (English)  
+49 89 92103 559 (German)  
+33 1 69 35 48 48 (French)  
[www.freescale.com/support](http://www.freescale.com/support)

### Japan:

Freescale Semiconductor Japan Ltd.  
Headquarters  
ARCO Tower 15F  
1-8-1, Shimo-Meguro, Meguro-ku,  
Tokyo 153-0064  
Japan  
0120 191014 or +81 3 5437 9125  
[support.japan@freescale.com](mailto:support.japan@freescale.com)

### Asia/Pacific:

Freescale Semiconductor China Ltd.  
Exchange Building 23F  
No. 118 Jianguo Road  
Chaoyang District  
Beijing 100022  
China  
+86 10 5879 8000  
[support.asia@freescale.com](mailto:support.asia@freescale.com)

### For Literature Requests Only:

Freescale Semiconductor Literature Distribution Center  
1-800-441-2447 or +1-303-675-2140  
Fax: +1-303-675-2150  
[LDCForFreescaleSemiconductor@hibbertgroup.com](mailto:LDCForFreescaleSemiconductor@hibbertgroup.com)

Information in this document is provided solely to enable system and software implementers to use Freescale Semiconductor products. There are no express or implied copyright licenses granted hereunder to design or fabricate any integrated circuits or integrated circuits based on the information in this document.

Freescale Semiconductor reserves the right to make changes without further notice to any products herein. Freescale Semiconductor makes no warranty, representation or guarantee regarding the suitability of its products for any particular purpose, nor does Freescale Semiconductor assume any liability arising out of the application or use of any product or circuit, and specifically disclaims any and all liability, including without limitation consequential or incidental damages. "Typical" parameters that may be provided in Freescale Semiconductor data sheets and/or specifications can and do vary in different applications and actual performance may vary over time. All operating parameters, including "Typicals", must be validated for each customer application by customer's technical experts. Freescale Semiconductor does not convey any license under its patent rights nor the rights of others. Freescale Semiconductor products are not designed, intended, or authorized for use as components in systems intended for surgical implant into the body, or other applications intended to support or sustain life, or for any other application in which the failure of the Freescale Semiconductor product could create a situation where personal injury or death may occur. Should Buyer purchase or use Freescale Semiconductor products for any such unintended or unauthorized application, Buyer shall indemnify and hold Freescale Semiconductor and its officers, employees, subsidiaries, affiliates, and distributors harmless against all claims, costs, damages, and expenses, and reasonable attorney fees arising out of, directly or indirectly, any claim of personal injury or death associated with such unintended or unauthorized use, even if such claim alleges that Freescale Semiconductor was negligent regarding the design or manufacture of the part.

Freescale™ and the Freescale logo are trademarks of Freescale Semiconductor, Inc. All other product or service names are the property of their respective owners.

© Freescale Semiconductor, Inc. 2009. All rights reserved.

