



# Model 2166 Preventive Maintenance/Gas Calibration

## Application Note A 67

- **Gas calibration** should be done a minimum of once every **six (6) months**. A calibration log where you record the unit's voltage and mA readings **BEFORE** any adjustments are made will help you to decide if the period between calibrations should be longer or shorter (see Application Notes **A24** and **A26**). See the spec for the full scale unit you are trying to calibrate for the 0 to 5 volt and 4 to 20 mA scale data response to carbon dioxide.
- A Mode **2166** should be mounted so that the water trap is toward the floor to allow gravity to collect water at the bottom of the clear plastic bowl. The Model 2166 has a switch to shut off the MV-610 pump so calibration flow rates can be lower than the 5 to 6 LPM pump rate (in the range of about 2 Liters per minute). Less calibration gas may be used if you inject the cal gas into the **INLET** side of the **Hydrophobic Filter**. You can use a flow rate between 0.3 and 0.5 liters per minute if you inject it into the hydrophobic filter. See Application Note **A73** for calibrating this way. It will make your calibration gas last much longer.

The water trap should be regularly inspected and cleaned. It has a replaceable paper filter element inside of it (**VALTRONICS** part # **0546**) and the complete water trap may be replaced if it is damaged. See list of parts on page 2 of this document. The **Hydrophobic Filter** # **0508** inside the unit should also be checked and replaced if clogged with water or dirty. The flow rate through the hydrophobic filter should be about 0.2 to 0.5 liters per minute. The frequency of this maintenance is dependent upon the environment that is being sampled. A very dirty environment will cause the filters to become clogged sooner. If the water trap filter becomes clogged, water may build up inside the trap and flow into the hydrophobic filter and clog it up. The output gas port should be vented to atmospheric pressure to avoid pressurizing the gas cell and causing span errors (see Application Note **A12** for effects of atmospheric pressure & temperature changes)

### Pneumatic Schematic

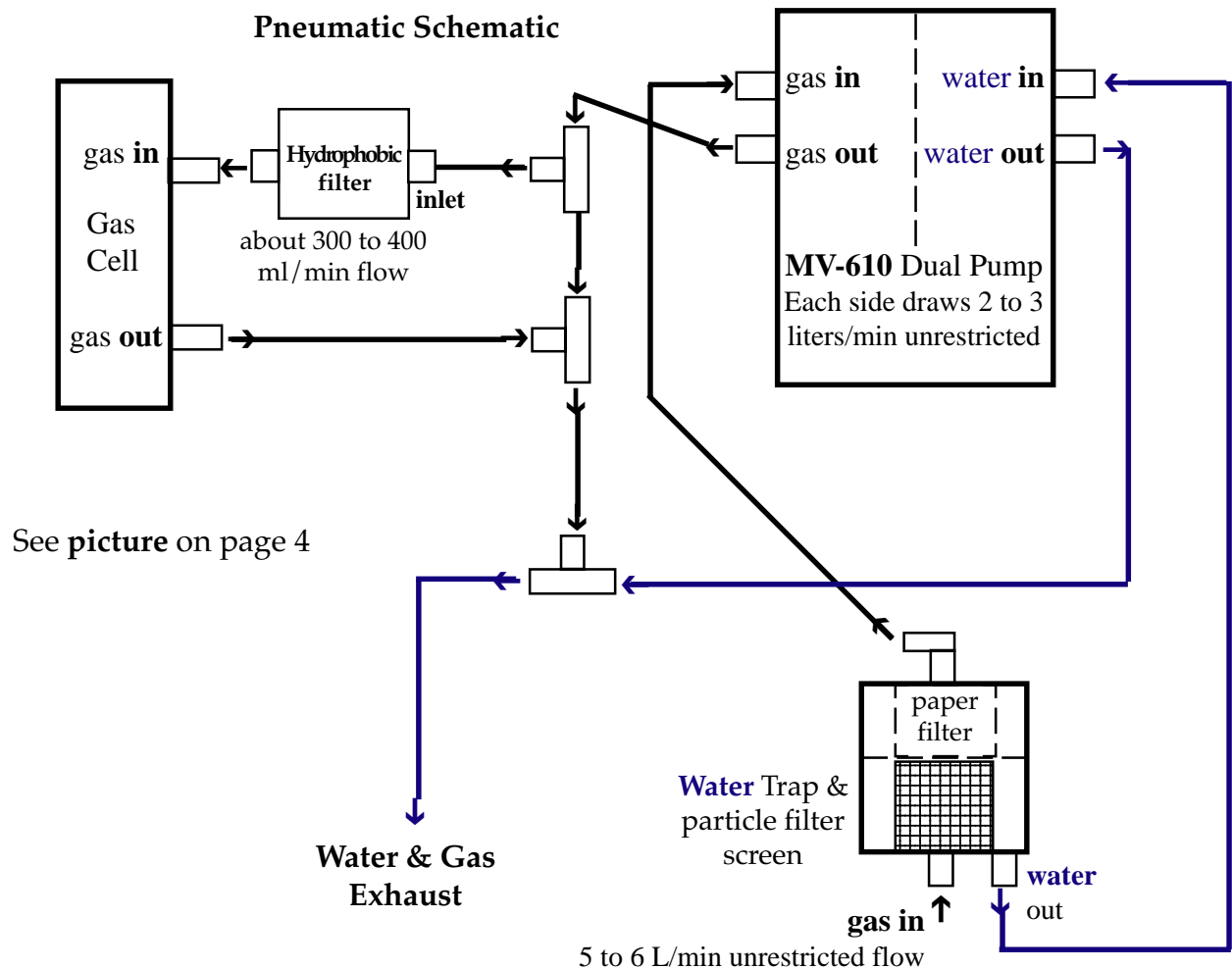

3463 Double Springs Road • Valley Springs, CA 95252 • (209) 754-0707 • FAX (209) 754-0104

Application Note A67, page 1 of 4 27-Jun-01 © 1994-2001 VALTRONICS



Revised Model 2166 April 20, 2000

Earlier versions of the Model 2166 have gas conditioning systems like the Model 2044 (see App Note A7)

Water Trap unscrewed 1/4 of a turn counter clockwise when view from sample gas input hose barb



Water Trap Assembly

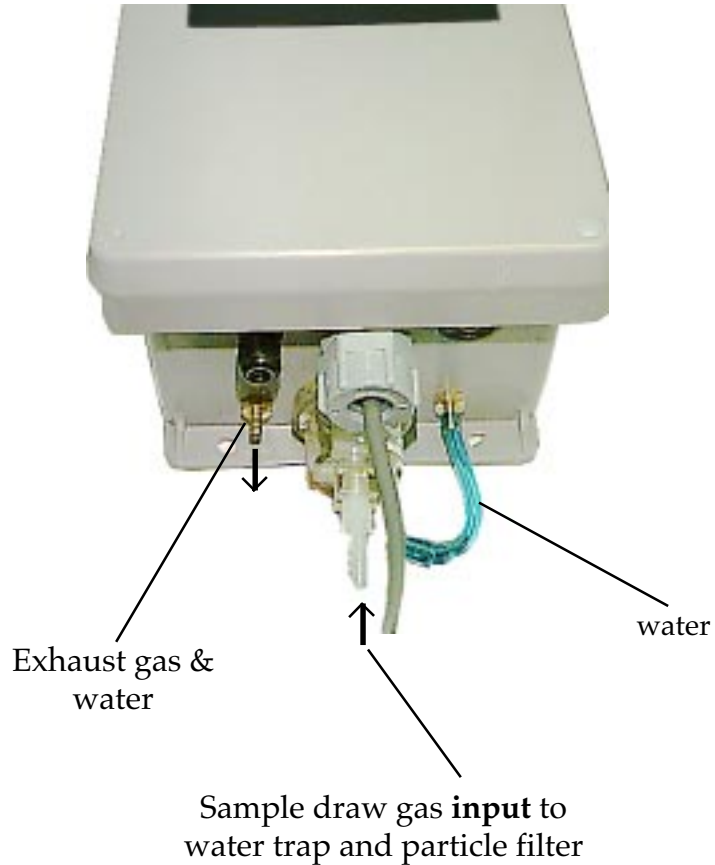

Use the 1 to 10 LPM Flow Meter (part # 0795) to check the pump flow rate at about 5 to 6 liters per minute unrestricted flow (long tubes connected to this gas inlet will restrict the flow to some degree) periodically

Filters inside of water trap should be checked periodically. The frequency depends upon the environment operated in. The screen should be cleaned with soap and water at a frequency that depends upon the amount of dirt drawn into input and the paper filter replaced when dirty.

**Application Note: A 67****Elements inside Water Trap**

**Paper Filter**  
(replace) #0546

**Screen Filter**  
(wash with soap & water)

1. **Water trap** and particle filter (ILND-6H05-011) is made by Finite Filter Co.
2. The Model 2166 has a **hydrophobic filter** SKU #0508 in front of the gas cell. It has one barb marked **INLET**.
3. The double chamber **Pump** (MV-610, 115V, 60Hz) is made by Enomoto Co. of Japan. Each pumping chamber is capable of creating about 3 liters per minute of unrestricted gas flow. With the filter restriction and the bypass, this pump will give about 200 to 500 ml per minute flow through the sample cell. Depending on the size and length of tubing, the gas inlet flow rate will be somewhere between 2 to 6 liters per minute.
4. The **Gas Cell** should be under a very small positive gauge pressure. This is accomplished by having the pump **push** the gas sample through the cell as opposed to pulling or sucking it through. Factory replacement of gas cells is recommended since they require temperature compensation on the mated circuit board as well as gas calibration. Coarse ZERO adjustment is required when the gas cell is replaced and this is accomplished using an oscilloscope to check TP2 for overshoot. See **Application Note A46** for details of all the circuit board adjustments.

List of **replacement parts**: (Note, training & test equipment is required to replace gas cells and to gas calibrate)

<b>VALTRONICS Part #</b>	<b>Description</b>
<b>0452</b>	<b>Power Transformer</b> for Model 2166
<b>0546</b>	<b>Paper Filter</b> inside water trap (2006, 2044, 2166)
<b>0545</b>	<b>Water Trap</b> (2006, 2044, 2166)
<b>0508</b>	<b>Hydrophobic Filter</b> (2166) can replace Dust Filter in Model 2044
<b>0401</b>	<b>Enomoto MV-610 pump, 115 VAC 50/60 Hz</b>
<b>0795</b>	<b>1 to 10 Liter per minute Flow Meter</b>
<b>030446</b>	<b>Gas Cell, 0.2% to 0.5% CO<sub>2</sub> (2166)</b> (factory replacement )
<b>030441</b>	<b>Gas Cell, 1% to 2% CO<sub>2</sub> (2166)</b> (factory replacement )
<b>030437</b>	<b>Gas Cell 3% to 20% CO<sub>2</sub> (2166)</b> (factory replacement )
<b>030353</b>	<b>Printed Circuit Board Assy (2166)</b> * Specify full scale for display scaling
<b>030421</b>	<b>LED Display, 3.5 digit,+ 3 indicators (2166)*</b> *Specify full scale for display (decimal point)

