

XFL225D Miniature Load Cell



- **0-10 to 0-5kN [0-2 Lbf to 0-1kLbf]**
- **Compression**
- **Very Flat**
- **Diameter 25mm [0.98"]**
- **Load Washer Model**
- **For Static and Dynamic Applications**
- **Strain Relief Spring**

DESCRIPTION

The XFL225D series is a very flat miniature load cell with a temperature compensation module integrated into the output cable. This design allows Measurement-Specialties to manufacture extremely small sensors without sacrificing thermal zero and sensitivity performance. The sensing element is fitted with a fully temperature compensated Wheatstone bridge equipped with high stability micro-machined silicon strain gages. The XFL225D is developed for measuring large full scale ranges up to 1000 lb and can withstand considerable overloads. It can measure strain during compression in static and dynamic applications. A strain relief spring strengthens the cable output. This sensor is available in a load washer model (the diameter of the hole is 8.2 mm) to measure bolt tightening forces.

With many years of experience as a designer and manufacturer of sensors, Measurement Specialties, Inc. often works with customers to design or customize sensors for specific uses and testing environments.

To meet your needs we also offer complete turnkey systems. The matched components (sensor, power, amplifier and digital display) are formatted, calibrated and ready for immediate use.

FEATURES

- Small size
- Flat sensor
- Inside hole Φ 8mm
- Other designs as special on request
- Temperature compensated

APPLICATIONS

- Strain table measurement
- Micro component assembly tools
- Screw and insert test benches
- Press fit monitoring
- Laboratory

STANDARD RANGES

F.S. Ranges in N	10 to 20 to 50 to 100	200 to 500 to 1k	2k to 5k
F.S. Ranges in Lbf	2 to 4 to 10 to 20	40 to 100 to 200	400 to 1k
Stiffness in N/m	1.1×10^5 to 5.8×10^6	2.0×10^7 to 7.3×10^8	2.0×10^7 to 7.3×10^8
Stiffness in Lbf/ft	6.9×10^3 to 4.0×10^5	1.4×10^5 to 5.0×10^7	1.4×10^5 to 5.0×10^7
Materials	Aluminum	Stainless Steel	

XFL225D Miniature Load Cell

PERFORMANCE SPECIFICATIONS

Ambient Temperature: 20±1°C (unless otherwise specified)

PARAMETERS	
Operating Temperature Range (OTR)	-40 to 120 °C [-40 to 248 °F]
Compensated Temperature Range (CTR)	0 to 60 °C (32 to 140 °F)
Zero Shift in CTR	<2% F.S. /60 °C [108 °F]
Sensitivity Shift in CTR	<2% of reading / 60 °C [108 °F]
Range (F.S.)	0-10N to 0-5kN [0-2 Lbf to 0-1000 Lbf]
Over-Range	
Without Damage	2 x F.S.
Without Destruction	3 x F.S.
Accuracy	
Linearity	≤±1% F.S.
Hysteresis	≤±1% F.S.

Electrical Characteristics

Model	XFL225D
Supply Outage	10Vdc
F.S. Output	100 mV
Zero Offset	<±10 mV
Input Impedance/Consumption	1000 to 3000Ω
Output Impedance	500 to 1000Ω
Insulation under 50Vdc	≥100MΩ

Notes

1. Electrical Termination: Cable: Shielded cable with 4 Teflon wires (AWG36), standard length 2 m [6.5 ft] with strain relief spring ; Compensation module at 1m [3.25 ft] from transducer
2. Material: Body in stainless steel or aluminum alloy depending on F.S.
3. Protection Index: IP50

XFL225D Miniature Load Cell

DIMENSIONS & WIRING SCHEMATIC (IN METRIC AND IMPERIAL)

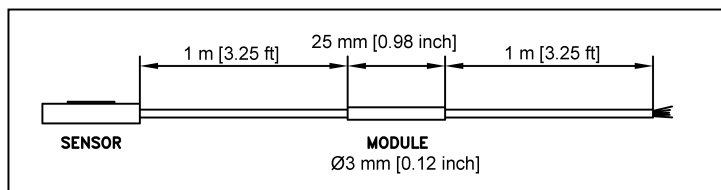
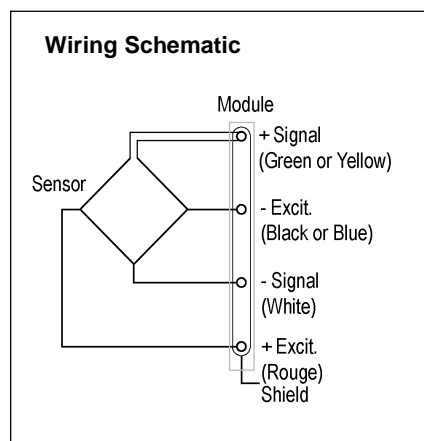
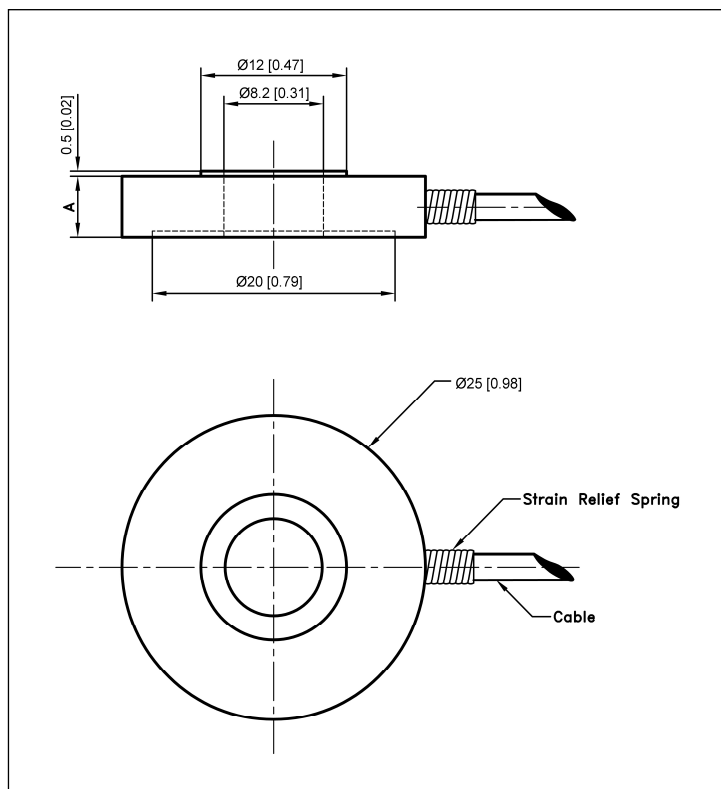

Dimensions in mm [inch]

F.S. Ranges in N [in Lbf]	10 - 20 - 50 - 100 [2 - 4 - 10 - 20]	200 - 500 - 1000 [40 - 100 - 200]	2000 - 5000 [400 - 1000]
A	3 [0.12]		5 [0.2]
Material	Aluminium Alloy	Stainless Steel	Stainless Steel
Stiffness in N/m	1.1×10^5 to 5.8×10^6	2.0×10^7 to 7.3×10^8	2.0×10^7 to 7.3×10^8
Stiffness in Lbf/ft	6.9×10^3 to 4×10^5	1.4×10^6 to 5×10^7	1.4×10^6 to 5×10^7

XFL225D Miniature Load Cell

OPTIONS

ET1 : CTR -20 to 100 °C [-4 to 212 °F]
ET2 : CTR -40 to 120 °C [-40 to 248 °F]
ET3 : CTR -40 to 150 °C [-40 to 302 °F] OTR=CTR (sta inless steel only)
LC"x": Additional cable length to standard length (in m) (Note : "X" = Custom value)
* Order Flat Force application surface with reference XFL205.

ORDERING INFO

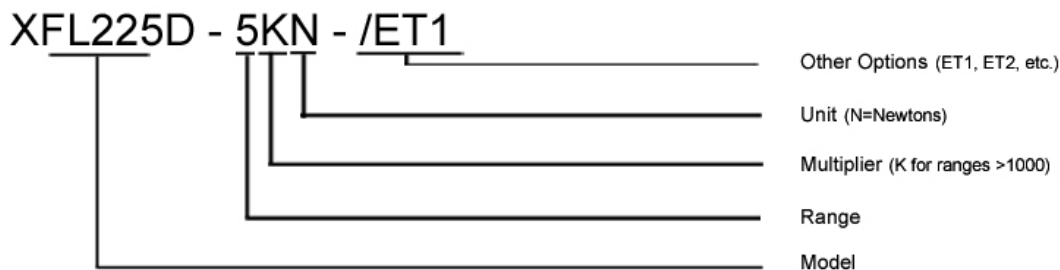

The information in this sheet has been carefully reviewed and is believed to be accurate; however, no responsibility is assumed for inaccuracies. Furthermore, this information does not convey to the purchaser of such devices any license under the patent rights to the manufacturer. Measurement Specialties, Inc. reserves the right to make changes without further notice to any product herein. Measurement Specialties, Inc. makes no warranty, representation or guarantee regarding the suitability of its product for any particular purpose, nor does Measurement Specialties, Inc. assume any liability arising out of the application or use of any product or circuit and specifically disclaims any and all liability, including without limitation consequential or incidental damages. Typical parameters can and do vary in different applications. All operating parameters must be validated for each customer application by customer's technical experts. Measurement Specialties, Inc. does not convey any license under its patent rights nor the rights of others.