

**PACKAGE DIMENSIONS** inch (mm)

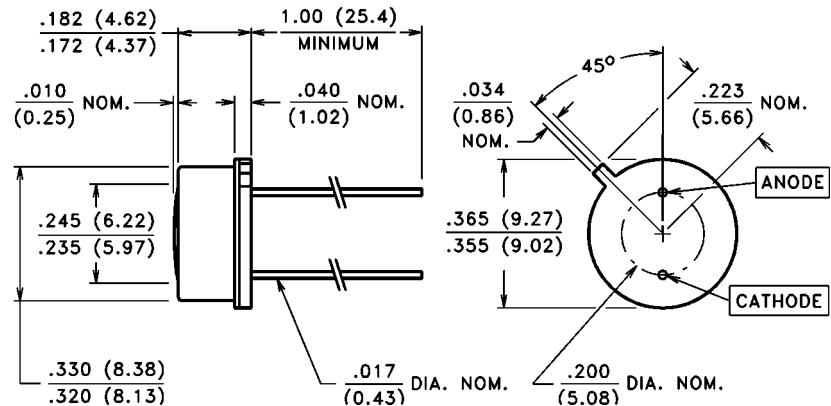

CASE 14 TO-5 HERMETIC  
CHIP ACTIVE AREA: .012 in<sup>2</sup> (7.45 mm<sup>2</sup>)

**PRODUCT DESCRIPTION**

Planar silicon photodiode in a "flat" window, dual lead TO-5 package. Cathode is common to the case. These diodes exhibit low dark current under reverse bias and fast speed of response.

**ABSOLUTE MAXIMUM RATINGS**

Storage Temperature: -40°C to 110°C  
Operating Temperature: -40°C to 110°C

**RoHS Compliant**



**ELECTRO-OPTICAL CHARACTERISTICS @ 25°C** (See also VTP curves, pages 45-46)

SYMBOL	CHARACTERISTIC	TEST CONDITIONS	VTP5050H			UNITS
			Min.	Typ.	Max.	
I <sub>SC</sub>	Short Circuit Current	H = 100 fc, 2850 K	40	70		μA
TC I <sub>SC</sub>	I <sub>SC</sub> Temperature Coefficient	2850 K		.20		%/°C
V <sub>OC</sub>	Open Circuit Voltage	H = 100 fc, 2850 K		350		mV
TC V <sub>OC</sub>	V <sub>OC</sub> Temperature Coefficient	2850 K		-2.0		mV/°C
I <sub>D</sub>	Dark Current	H = 0, VR = 50 V			18	nA
R <sub>SH</sub>	Shunt Resistance	H = 0, V = 10 mV		.25		GΩ
C <sub>J</sub>	Junction Capacitance	H = 0, V = 15 V			24	pF
Re	Responsivity	940 nm		.05		A/(W/cm <sup>2</sup> )
S <sub>R</sub>	Sensitivity	@ Peak		.55		A/W
λ <sub>range</sub>	Spectral Application Range		400		1150	nm
λ <sub>p</sub>	Spectral Response - Peak			925		nm
V <sub>BR</sub>	Breakdown Voltage		50	140		V
θ <sub>1/2</sub>	Angular Resp. - 50% Resp. Pt.			±45		Degrees
NEP	Noise Equivalent Power			1.4 x 10 <sup>-13</sup> (Typ.)		W/√Hz
D*	Specific Detectivity			2.0 x 10 <sup>12</sup> (Typ.)		cm√Hz/W