

PACKAGE DIMENSIONS inch (mm)

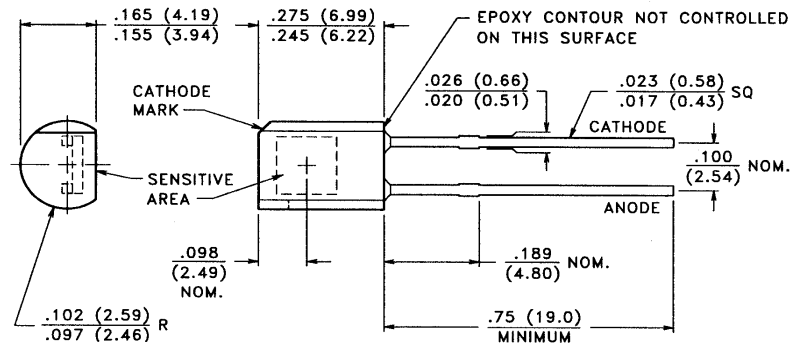

CASE 61 TO-92 TYPE (FLAT LENS)
CHIP ACTIVE AREA: .011 in² (7.41 mm²)

PRODUCT DESCRIPTION

Large area planar silicon photodiode in a cast epoxy sidelooper, similar in outline to the TO-92 package. The package material filters out all visible light but passes infrared. These diodes exhibit low dark current under reverse bias and fast speed of response.

ABSOLUTE MAXIMUM RATINGS

Storage Temperature: -40°C to 100°C
Operating Temperature: -40°C to 100°C

RoHS Compliant



ELECTRO-OPTICAL CHARACTERISTICS @ 25°C

SYMBOL	CHARACTERISTIC	TEST CONDITIONS	VTD206H			UNITS
			Min.	Typ.	Max.	
I _{SC}	Short Circuit Current	940 nm, H = 0.5 mW/cm ²	15	25		μA
TC I _{SC}	I _{SC} Temperature Coefficient	2856 K		.20		%/°C
V _{OC}	Open Circuit Voltage	940 nm, H = 0.5 mW/cm ²	250	350		mV
TC V _{OC}	V _{OC} Temperature Coefficient	2856 K		-2.6		mV/°C
I _D	Dark Current	H = 0, V _R = 10 V		2	30	nA
C _J	Junction Capacitance	H = 0, V _R = 0 V, 1 MHz		72		pF
t _R /t _F	Rise/Fall Time @ RL = 50Ω	V _R = 5 V, 850 nm		20		nsec
S _R	Sensitivity	@ Peak		0.6		A/W
λ _{range}	Spectral Application Range		750		1100	nm
λ _p	Spectral Response - Peak			925		nm
V _{BR}	Breakdown Voltage		20	50		V
θ _{1/2}	Angular Resp.-50% Resp. Pt.			±60		Degrees